

HP Mini 1101, HP Mini 110, HP Mini 110  
by Studio Tord Boontje, and Compaq Mini  
110

Maintenance and Service Guide

© Copyright 2009 Hewlett-Packard  
Development Company, L.P.

Bluetooth is a trademark owned by its proprietor and used by Hewlett-Packard Company under license. Intel and Atom are trademarks of Intel Corporation in the U.S. and other countries. Microsoft, Windows, and Windows Vista are U.S. registered trademarks of Microsoft Corporation. SD Logo is a trademark of its proprietor.

The information contained herein is subject to change without notice. The only warranties for HP products and services are set forth in the express warranty statements accompanying such products and services. Nothing herein should be construed as constituting an additional warranty. HP shall not be liable for technical or editorial errors or omissions contained herein.

Second Edition: October 2009

First Edition: May 2009

Document Part Number: 537033-001  
Revision A

## Revision history

Revision	Publication date	Description
A	October 2009	<ul style="list-style-type: none"><li>• Chapter 1 — Updated to incorporate Windows 7 and the HP Mini 110 by Studio Tord Boontje</li><li>• Chapter 3 — New and updated spare parts and descriptions</li><li>• Chapter 4 — New and updated spare parts and descriptions</li><li>• Chapter 6 — Updated to incorporate revisions to hard drive specifications and the addition of WSVGA display specifications</li><li>• Chapter 8 — Updated to incorporate Windows 7 backup and recovery procedures</li></ul>



## Safety warning notice

- 
- ⚠ **WARNING!** To reduce the possibility of heat-related injuries or of overheating the device, do not place the device directly on your lap or obstruct the device air vents. Use the device only on a hard, flat surface. Do not allow another hard surface, such as an adjoining optional printer, or a soft surface, such as pillows or rugs or clothing, to block airflow. Also, do not allow the AC adapter to contact the skin or a soft surface, such as pillows or rugs or clothing, during operation. The device and the AC adapter comply with the user-accessible surface temperature limits defined by the International Standard for Safety of Information Technology Equipment (IEC 60950).
-



---

# Table of contents

## 1 Product description

## 2 External component identification

Top components .....	5
TouchPad .....	5
Light .....	6
Keys .....	7
Front components .....	9
Right-side components .....	11
Left-side components .....	12
Display components .....	13
Bottom components .....	14
Wireless antennas .....	15

## 3 Illustrated parts catalog

Service tag .....	16
Device major components .....	17
Display assembly components .....	25
Mass storage devices .....	27
Miscellaneous parts .....	28
Sequential part number listing .....	29

## 4 Removal and replacement procedures

Preliminary replacement requirements .....	37
Tools required .....	37
Service considerations .....	37
Plastic parts .....	37
Cables and connectors .....	37
Drive handling .....	38
Grounding guidelines .....	39
Electrostatic discharge damage .....	39
Packaging and transporting guidelines .....	40
Workstation guidelines .....	40

Equipment guidelines .....	41
Component replacement procedures .....	42
Service tag .....	42
Device feet .....	43
Battery .....	44
SIM .....	45
Memory module .....	46
Keyboard .....	48
RTC battery .....	53
Mass storage devices .....	54
Hard drive .....	55
Solid-state drive .....	55
Top cover .....	57
WLAN module .....	60
WWAN module .....	62
USB/audio board .....	64
Power/battery pass-through board .....	66
Fan .....	68
Heat sink assembly .....	70
System board .....	72
Display assembly .....	75

## 5 Setup Utility

Starting the Setup Utility .....	83
Using the Setup Utility .....	83
Changing the language of the Setup Utility .....	83
Navigating and selecting in the Setup Utility .....	83
Displaying system information .....	84
Restoring default settings in the Setup Utility .....	84
Exiting the Setup Utility .....	84
Setup Utility menus .....	85
Main menu .....	85
Security menu .....	85
System Configuration menu .....	85
Diagnostics menu .....	86

## 6 Specifications

Device specifications .....	87
10.1-inch, AntiGlare display specifications .....	88
10.1-inch, WSVGA, AntiGlare display specifications .....	89
Hard drive specifications .....	90
Solid-state drive specifications .....	91
System DMA specifications .....	92



System interrupt specifications .....	93
System I/O address specifications .....	94
System memory map specifications .....	96

## 7 Screw listing

Phillips PM1.5×1.0 screw .....	97
Phillips PM2.0×3.0 screw .....	99
Phillips PM2.0×3.0 captive screw .....	101
Phillips PM2.0×4.0 screw .....	102
Phillips PM2.0×5.0 screw .....	103
Phillips PM2.5×5.0 screw .....	104
Phillips PM2.5×7.0 screw .....	106
Phillips PM2.5×10.0 captive screw .....	107
Phillips PM3.0×4.0 screw .....	108

## 8 Backup and recovery

Mobile Mi backup and recovery .....	110
Backing up your information .....	110
When to back up .....	110
Restoring your information .....	110
Using System Restore .....	111
Using HP Mi Restore Image Creator .....	111
Restoring using a Windows computer .....	111
Restoring using a Linux computer .....	112
Windows 7 backup and recovery .....	114
Backing up and recovering using Roxio BackOnTrack .....	114
Creating a copy of the hard drive .....	114
Performing a recovery .....	115
Using the Disaster Recovery utility .....	115
Downloading and extracting the Disaster Recovery utility .....	115
Restoring your hard drive image .....	116
Using the Instant Restore utility .....	116
Using the Instant Restore utility when the operating system is functioning .....	116
Using the Instant Restore utility when the operating system is not functioning .....	117
Using Windows Backup and Restore .....	117
Using system restore points .....	117
When to create restore points .....	117
Creating a system restore point .....	117
Restoring to a previous date and time .....	118
Backing up and recovering using HP Recovery Manager .....	118
Backing up your information .....	118

Creating a set of recovery discs .....	119
Performing a recovery .....	120
Recovering using the recovery discs .....	120
Recovering using the partition on the hard drive (select models only) .....	120
Windows Vista backup and recovery .....	122
Backing up your information .....	122
Performing a recovery .....	123
Using the Windows recovery tools .....	124
Using f11 .....	125
Using a Windows Vista operating system DVD (purchased separately) .....	125
Windows XP backup and recovery .....	126
Backing up your information .....	126
Performing a recovery .....	127
Recovering your information .....	127
Recovering the operating system and programs .....	127

## 9 Connector pin assignments

Audio-in (microphone) .....	128
Audio-out (headphone) .....	129
External monitor .....	130
RJ-45 (network) .....	131
Universal Serial Bus .....	132

## 10 Power cord set requirements

Requirements for all countries and regions .....	133
Requirements for specific countries and regions .....	134

## 11 Recycling

Battery .....	135
Display .....	135

<b>Index .....</b>	<b>141</b>
--------------------	------------

# 1 Product description

Category	Description	HP Mini 1101	HP Mini 110	HP Mini 110 by Studio Tord Boontje	Compaq Mini 110
<b>Product name</b>	HP Mini 1101	√			
	HP Mini 110		√		
	HP Mini 110 by Studio Tord Boontje			√	
	Compaq Mini 110				√
<b>Processor</b>	Intel® Atom™ N280 1.66-GHz processor, 512-KB Level 2 cache, 533-MHz front-side bus (FSB)	√	√	√	√
	Intel Atom N270 1.6-GHz processor, 512-KB Level 2 cache, 533-MHz front-side bus (FSB)	√	√	√	√
<b>Chipset</b>	Northbridge: 945GSE; 533-MHz bus speed	√	√	√	√
	Southbridge: ICH7M	√	√	√	√
<b>Graphics</b>	Intel® Graphics Media Accelerator 950	√	√	√	√
	Universal Memory Architecture (UMA) graphics subsystem	√	√		√
<b>Panels</b>	All display assemblies include 1 webcam, 1 microphone, 1 speaker box, and 2 wireless local-area network (WLAN) antenna transceivers/cables; wireless wide-area network (WWAN) is optional for HP Mini 110 and Compaq Mini 110 models	√	√	√	√
	Wide aspect 16:9 ratio panels	√	√	√	√
	10.1-inch high-definition AntiGlare (1366 × 768) LED	√	√	√	√
	10.1-inch standard-definition AntiGlare (1024 × 576) LED	√	√		√

Category	Description	HP Mini 1101	HP Mini 110	HP Mini 110 by Studio Tord Boontje	Compaq Mini 110
	10.1-inch WSVGA (1024 × 600) LED	√	√	√	√
<b>Memory</b>	One customer-accessible/upgradable memory module slot	√	√	√	√
	Supports up to 2 GB of system memory	√	√	√	√
	PC2-4200, 533-MHz, DDR2	√	√	√	√
	Supports the following configurations:				
	<ul style="list-style-type: none"> <li>1024-MB total system memory (1024 × 1)</li> <li>2048-MB total system memory (2048 × 1)</li> </ul>	√	√	√	√
<b>Mass storage devices</b>	Solid-state drive (SSD) based on multi-level cell (MLC) technology	√	√	√	√
	32-GB	√	√	√	√
<b>Hard drive</b>	Supports all 9.5-mm, 6.35-cm (2.50-inch) parallel SATA hard drives (optional)	√	√	√	√
	320-GB, 5400-RPM		√	√	√
	<b>NOTE:</b> Not supported by computers with Windows® XP Home SP3, ultra low-cost personal computer (ULCPC) edition installed.				
	250-GB, 5400-RPM	√	√	√	√
	<b>NOTE:</b> Not supported by computers with Windows XP Home SP3, ultra low-cost personal computer (ULCPC) edition installed.				
	160-GB, 7200-RPM		√	√	√
	160-GB, 5400-RPM	√	√	√	√
<b>Optical drive</b>	Supports external USB optical drives only	√	√	√	√
<b>Diskette drive</b>	Supports external USB diskette drives only	√	√	√	√
<b>Audio/Visual</b>	high-definition (HD) audio	√	√	√	√
	Integrated speakers (2)	√	√	√	√
	Fixed integrated microphone	√	√	√	√
	Fixed integrated VGA webcam, 640 × 480 resolution, up to 30 frames per second	√	√	√	√

Category	Description	HP Mini 1101	HP Mini 110	HP Mini 110 by Studio Tord Boontje	Compaq Mini 110
<b>Modem</b>	Supports external USB modems only	√	√	√	√
<b>Ethernet</b>	Integrated 10/100 network interface card (NIC)	√	√	√	√
<b>Wireless</b>	2 WLAN antennas built into display assembly	√	√	√	√
	Integrated WLAN by way of 802.11b/g/n and 802.11b/g WLAN modules	√	√	√	√
	Integrated WWAN by way of HP un2400 Mobile Broadband Module (optional)	√	√	√	√
	<b>NOTE:</b> Not available in HP Mini 110 models with Mobile Mi installed.				
<b>External media cards</b>	Digital Media Slot (consumer models) or Media Card Reader (commercial models) with push-push technology supporting: <ul style="list-style-type: none"> <li>• Memory Stick (MS)</li> <li>• Memory Stick Pro (MSP)</li> <li>• MultiMediaCard (MMC)</li> <li>• Secure Digital (SDHC) Memory Card</li> <li>• xD-Picture Card (XD)</li> </ul>	√	√	√	√
<b>Internal media cards</b>	Two Mini Card slots: <ul style="list-style-type: none"> <li>• Full-size Mini Card slot</li> <li>• Half-size Mini Card slot</li> </ul>	√	√	√	√
<b>Ports</b>	Audio-in/out (microphone/stereo headphone)	√	√	√	√
	RJ-45 (Ethernet, includes link and activity lights)	√	√	√	√
	USB (3)	√	√	√	√
	3-pin AC power	√	√	√	√
<b>Keyboard/ pointing device</b>	92% keyboard	√	√	√	√
	TouchPad, with 2 TouchPad buttons and 2-way scrolling (taps enabled by default)	√	√	√	√

Category	Description	HP Mini 1101	HP Mini 110	HP Mini 110 by Studio Tord Boontje	Compaq Mini 110
<b>Power requirements</b>	30-W UMA AC adapter (non-Smart) with localized cable plug support	√	√	√	√
	AC adapter connector on cable	√	√	√	√
	6-cell lithium-polymer (Li-Pol) battery (2.55-Ah, 55-Wh), 6-hour target life	√	√	√	√
	3-cell lithium-polymer (Li-Pol) battery (2.55-Ah, 28-Wh), 3-hour target life	√	√	√	√
<b>Security</b>	Supports HP Kensington Security Lock	√	√	√	√
<b>Operating system</b>	<b>Preinstalled:</b>				
	Windows 7 Basic 32		√	√	√
	Windows 7 Starter 32		√	√	√
	Windows XP Home SP3, ultra low-cost personal computer (ULCPC) edition	√	√	√	√
	Windows Vista® Business 32 (with XP Pro image)	√			
	HP Mobile Mi		√		
<b>Serviceability</b>	<b>End-user replaceable parts:</b>				
	AC adapter	√	√	√	√
	Battery (system)	√	√	√	√
	Hard drive	√	√	√	√
	Keyboard	√	√	√	√
	Memory module	√	√	√	√
	Solid-state drive	√	√	√	√

## 2 External component identification

Components included with the device may vary by region and model. The illustrations in this chapter identify the standard features on most device models.

### Top components

#### TouchPad

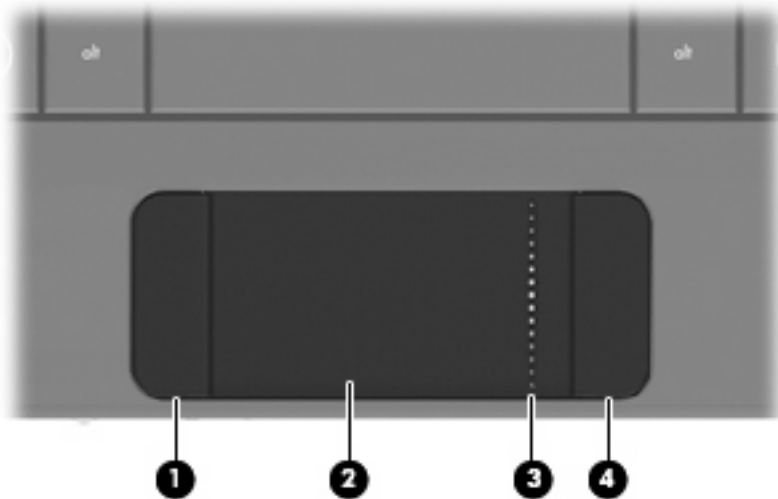

Component	Description
(1) Left TouchPad button	Functions like the left button on an external mouse.
(2) TouchPad	Moves the pointer and selects or activates items on the screen.
(3) TouchPad scroll zone	Scrolls up or down.
(4) Right TouchPad button	Functions like the right button on an external mouse.

## Light

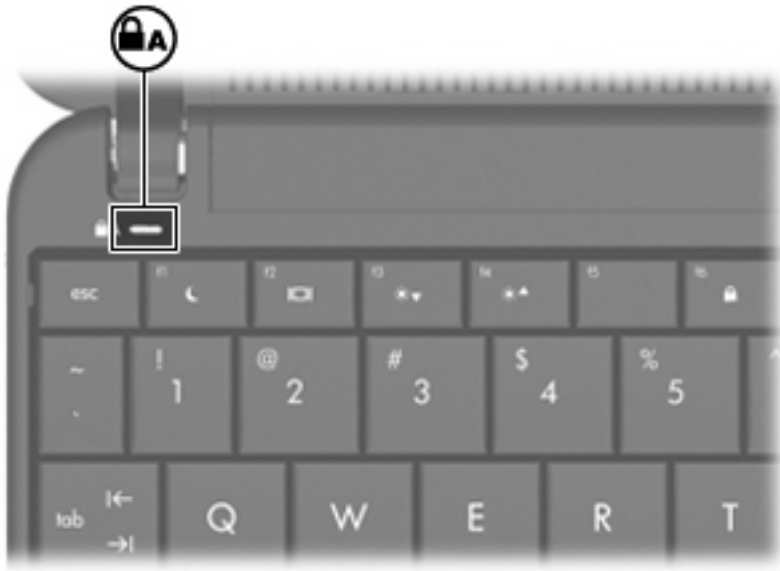

Component	Description
Caps lock light	On: Caps lock is on.



## Keys

 **NOTE:** Refer to the illustration that most closely matches your computer.

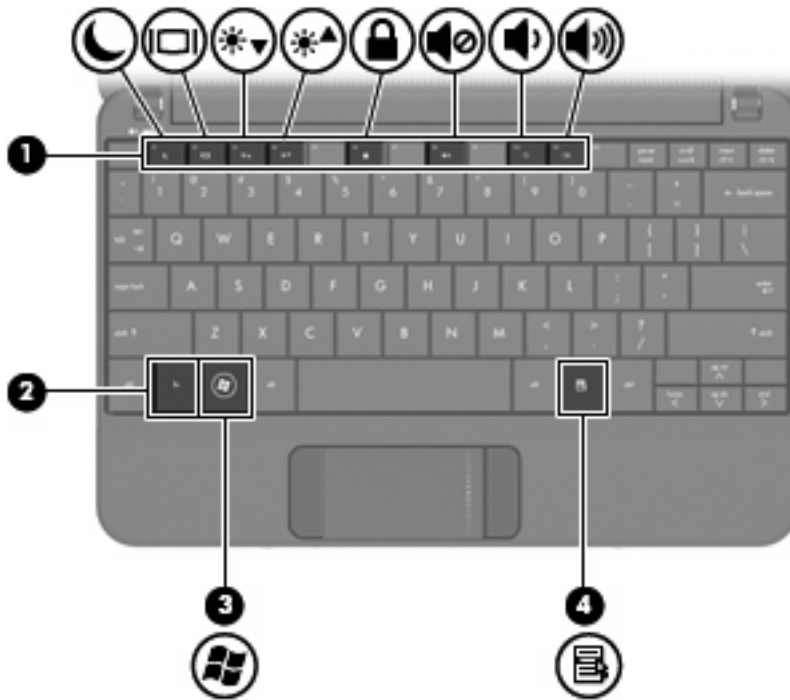

Component	Description
(1) Function keys	Execute frequently used system functions when pressed in combination with the <b>fn</b> key.
(2) <b>fn</b> key	Executes frequently used system functions when pressed in combination with a function key.
(3) Windows® logo key	Displays the Windows Start menu.
(4) Windows applications key	Displays a shortcut menu for items beneath the pointer.

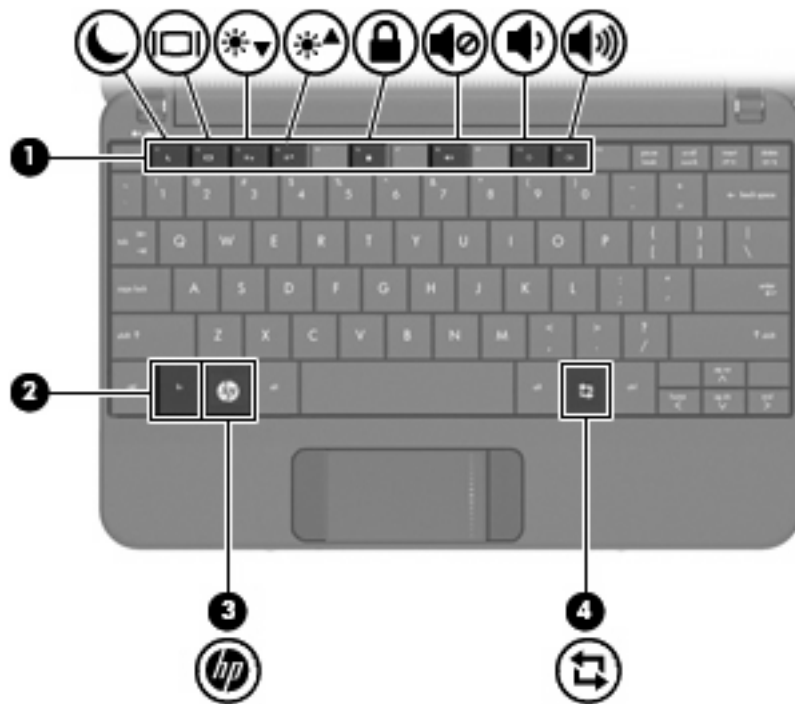

Component		Description
(1)	Function keys	Execute frequently used system functions when pressed in combination with the <b>fn</b> key.
(2)	<b>fn</b> key	Executes frequently used system functions when pressed in combination with a function key.
(3)	Home key	Returns to the Home Screen.
(4)	Program Switcher key	Displays the Start New Program button from anywhere on the device.

## Front components

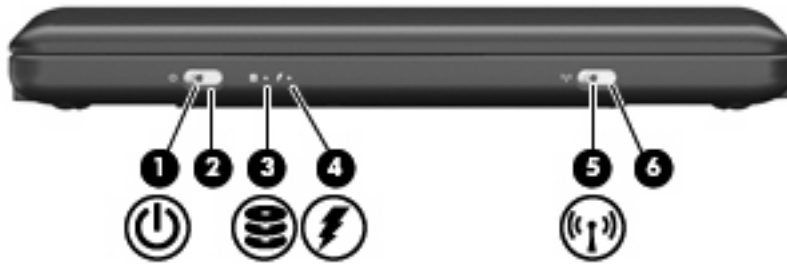

Component	Description
(1) Power light	<ul style="list-style-type: none"> <li>On: The device is on.</li> <li>Blinking: The device is in the Sleep state (Windows Vista) or Standby (Windows XP or Mobile Mi).</li> <li>Off: The device is off or in Hibernation.</li> </ul>
(2) Power switch	<ul style="list-style-type: none"> <li>When the device is off, slide the switch to turn on the device.</li> <li>When the device is on, briefly slide the switch to initiate Hibernation.</li> <li>When the device is in the Sleep state (Windows Vista) or Standby (Windows XP or Mobile Mi), briefly slide the switch to exit the Sleep state (Windows Vista) or Standby (Windows XP or Mobile Mi).</li> <li>When the device is in Hibernation, briefly slide the switch to exit Hibernation.</li> </ul> <p>If the device has stopped responding and operating system shutdown procedures are ineffective, slide and hold the power switch for at least 5 seconds to turn off the device.</p>
(3) Drive light	<p>Blinking: The hard drive or flash drive is being accessed.</p>
(4) Battery light	<ul style="list-style-type: none"> <li>On: A battery is charging.</li> <li>Blinking: A battery that is the available only power source has reached a low battery level. When the battery reaches a critical battery level, the battery light begins blinking rapidly.</li> <li>Off: If the device is plugged into an external power source, the light turns off when all batteries in the device are fully charged. If the device is not plugged into an external power source, the light stays off until the battery reaches a low battery level.</li> </ul>

Component		Description
(5)	Wireless light	<ul style="list-style-type: none"><li>• Blue: An integrated wireless device, such as a wireless local area network (WLAN) device, is on.</li><li>• Amber: All wireless devices are off.</li></ul>
(6)	Wireless switch	<p>Turns the wireless feature on or off, but does not establish a wireless connection.</p> <p><b>NOTE:</b> A wireless network must be set up in order to establish a wireless connection.</p>

## Right-side components

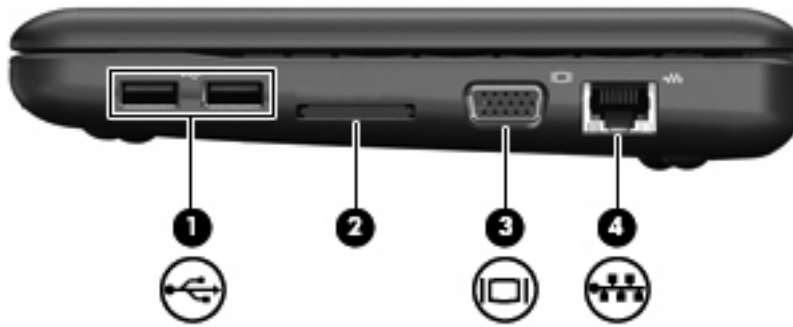

Component	Description
(1) USB ports (2)	Connect optional USB devices.
(2) Digital Media Slot (consumer models) or Media Card Reader (commercial models)	Supports the following optional digital card formats: <ul style="list-style-type: none"><li>• Memory Stick (MS)</li><li>• Memory Stick Pro (MSP)</li><li>• MultiMediaCard (MMC)</li><li>• Secure Digital (SD) Memory Card</li><li>• xD-Picture Card</li></ul>
(3) External monitor port	Connects an optional external display, such as a monitor or projector, to the device.
(4) RJ-45 (network) jack	Connects a network cable.

## Left-side components

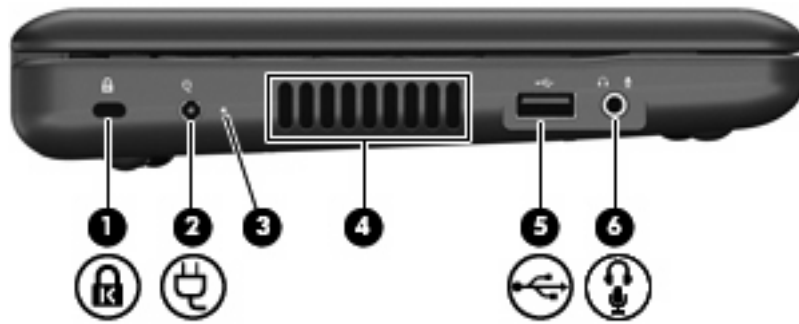

Component	Description
(1) Security cable slot	Attaches an optional security cable to the device.  <b>NOTE:</b> The security cable is designed to act as a deterrent, but it may not prevent the device from being mishandled or stolen.
(2) Power connector	Connects an AC adapter.
(3) AC adapter light	Indicates AC power connection.
(4) Vent	Enables airflow to cool internal components.  <b>NOTE:</b> The device fan starts up automatically to cool internal components and prevent overheating. It is normal for the internal fan to cycle on and off during routine operation.
(5) USB port	Connects an optional USB device.
(6) Audio-out (headphone) jack/Audio-in (microphone) jack	Produces sound when connected to optional powered stereo speakers, headphones, earbuds, a headset, or television audio. Also connects an optional headset microphone.  <b>WARNING!</b> To reduce the risk of personal injury, adjust the volume before putting on headphones, earbuds, or a headset. For additional safety information, refer to the <i>Regulatory, Safety and Environmental Notices</i> .  <b>NOTE:</b> When an audio component is connected to the jack, the device speakers are disabled.  The audio component cable must have a 4-conductor connector.

## Display components

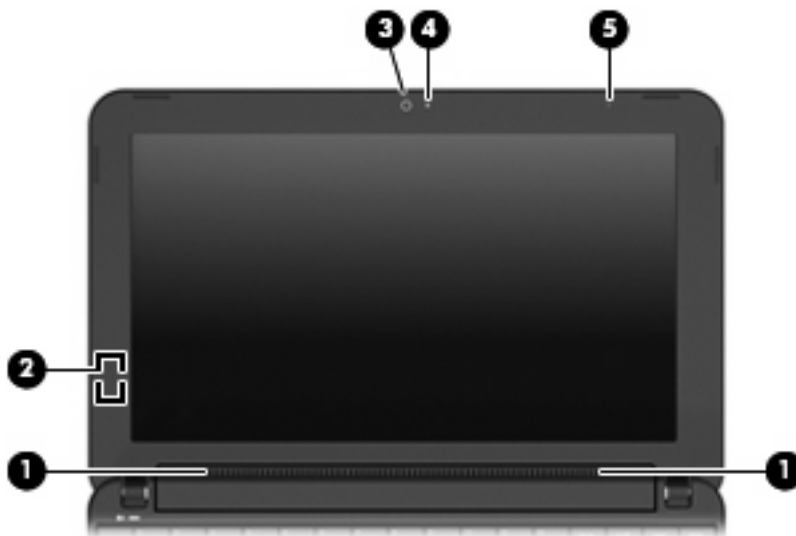

Component	Description
(1) Speakers (2)	Produce sound.
(2) Internal display switch	Turns off the display if the display is closed while the power is on. <b>NOTE:</b> The display switch is not visible from the outside of the device.
(3) Webcam	Captures still photographs and videos. <b>NOTE:</b> To capture videos, you need to install additional webcam software.
(4) Webcam light	On: The webcam is in use.
(5) Internal microphone	Records sound.

## Bottom components

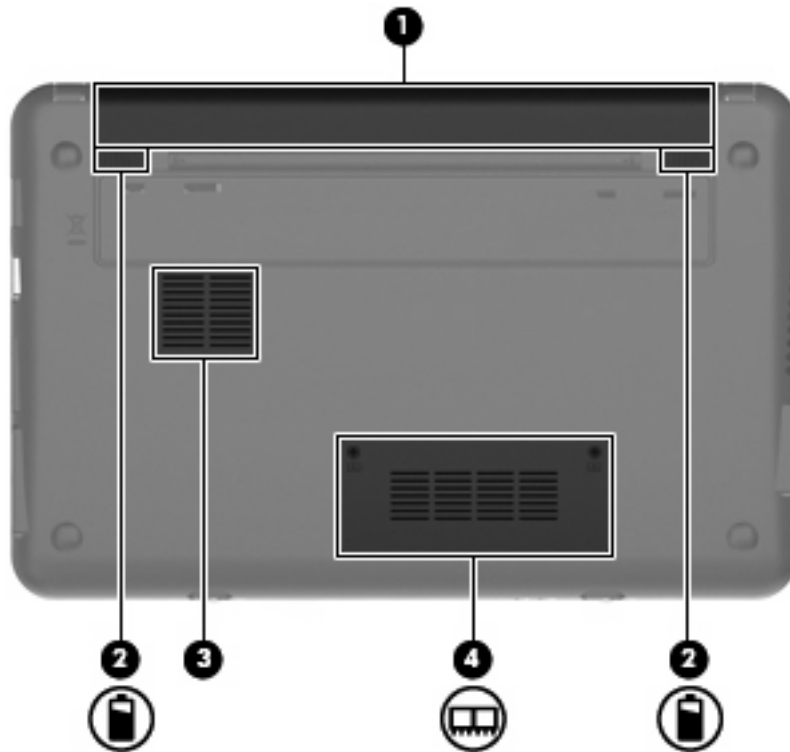

Component	Description
(1) Battery bay	Holds the battery.
(2) Battery release latches (2)	Release the battery from the battery bay.
(3) Vent	Enables airflow to cool internal components. <b>NOTE:</b> The device fan starts up automatically to cool internal components and prevent overheating. It is normal for the internal fan to cycle on and off during routine operation.
(4) Memory module compartment	Contains the memory module slot.



## Wireless antennas

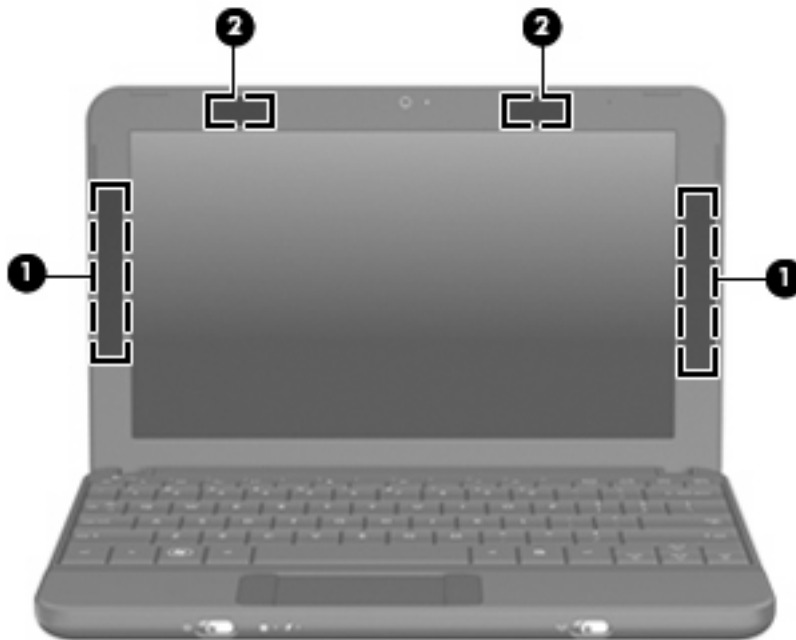

Component	Description
(1) WWAN antennas (2) (select models only)*	Send and receive wireless signals to communicate with wireless wide-area networks (WWANs). <b>NOTE:</b> This option is not available on computers with Mobile Mi installed.
(2) WLAN antennas (2)*	Send and receive wireless signals to communicate with wireless local area networks (WLANs).

\*The antennas are not visible from the outside of the device. For optimal transmission, keep the areas immediately around the antennas free from obstructions.

To see wireless regulatory notices, refer to the section of the *Regulatory, Safety and Environmental Notices* that applies to your country or region.

## 3 Illustrated parts catalog

### Service tag

When ordering parts or requesting information, provide the computer serial number and model description provided on the service tag:

- (1) Product name: This is the product name affixed to the front of the device.
- (2) Serial number (s/n): This is an alphanumeric identifier that is unique to each product.
- (3) Part number/Product number (p/n): This number provides specific information about the product's hardware components. The part number helps a service technician to determine what components and parts are needed.
- (4) Model description: This is the alphanumeric identifier used to locate documents, drivers, and support for the device.
- (5) Warranty period: This number describes the duration of the warranty period for the device.

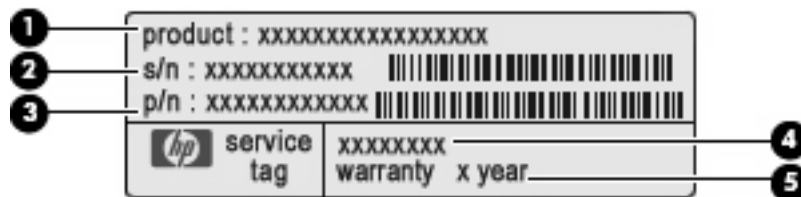

## Device major components

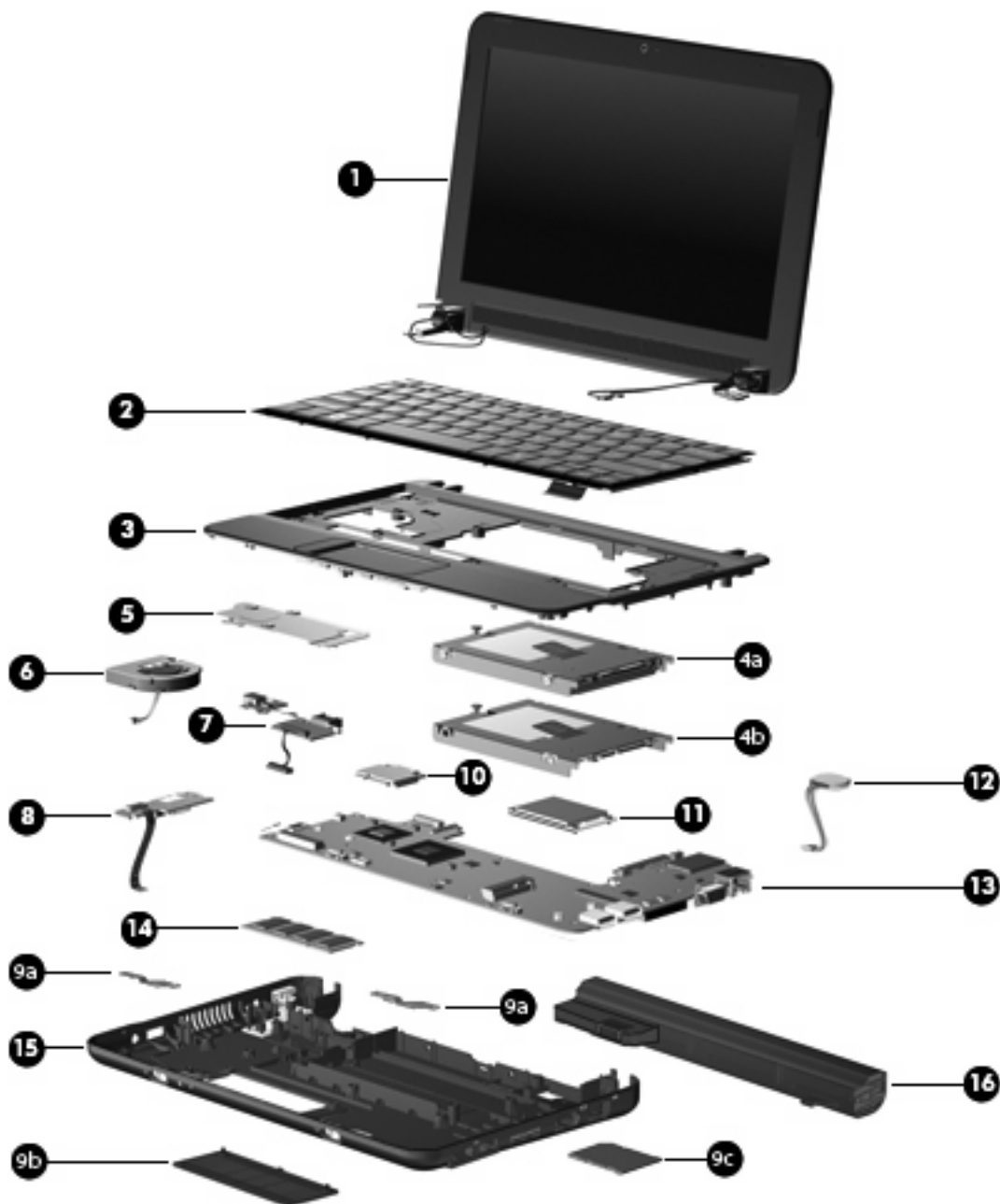

Item	Description	Spare part number
(1)	<p><b>Display assembly</b> (includes 1 webcam, 1 microphone, 1 speaker box, and 2 WLAN antenna transceivers/cables; WWAN on select models only)</p> <p>See <a href="#">Display assembly components on page 25</a> for a comprehensive list of display assembly spare parts.</p> <p>For use with black HP models only</p> <ul style="list-style-type: none"> <li>10.1-inch, high-definition, AntiGlare display assembly (includes WWAN)</li> <li>10.1-inch, high-definition, AntiGlare display assembly</li> </ul>	<p>572407-001</p> <p>572406-001</p>

<b>Item</b>	<b>Description</b>	<b>Spare part number</b>
	<ul style="list-style-type: none"> <li>10.1-inch, standard-definition, AntiGlare display assembly (includes WWAN)</li> </ul>	571414-001
	<ul style="list-style-type: none"> <li>10.1-inch, standard-definition, AntiGlare display assembly</li> </ul>	537646-001
	<ul style="list-style-type: none"> <li>10.1-inch, WSVGA, AntiGlare display assembly (includes WWAN)</li> </ul>	579604-001
	For use with pink HP models only	
	<ul style="list-style-type: none"> <li>10.1-inch, high-definition, AntiGlare display assembly (includes WWAN)</li> </ul>	572413-001
	<ul style="list-style-type: none"> <li>10.1-inch, standard-definition, AntiGlare display assembly (includes WWAN)</li> </ul>	571416-001
	<ul style="list-style-type: none"> <li>10.1-inch, WSVGA, AntiGlare display assembly (includes WWAN)</li> </ul>	579608-001
	For use with white HP models only	
	<ul style="list-style-type: none"> <li>10.1-inch, high-definition, AntiGlare display assembly (includes WWAN)</li> </ul>	572411-001
	<ul style="list-style-type: none"> <li>10.1-inch, standard-definition, AntiGlare display assembly (includes WWAN)</li> </ul>	571415-001
	<ul style="list-style-type: none"> <li>10.1-inch, WSVGA, AntiGlare display assembly (includes WWAN)</li> </ul>	579606-001
	For use with blue HP models only	
	<ul style="list-style-type: none"> <li>10.1-inch, high-definition, AntiGlare display assembly (includes WWAN)</li> </ul>	591647-001
	<ul style="list-style-type: none"> <li>10.1-inch, WSVGA, AntiGlare display assembly (includes WWAN)</li> </ul>	591648-001
	For use with HP Mini 110 by Studio Tord Boontje models only	
	<ul style="list-style-type: none"> <li>10.1-inch, high-definition, AntiGlare display assembly (includes WWAN)</li> </ul>	579612-001
	<ul style="list-style-type: none"> <li>10.1-inch, standard-definition, AntiGlare display assembly (includes WWAN)</li> </ul>	579610-001
	<ul style="list-style-type: none"> <li>10.1-inch, WSVGA, AntiGlare display assembly (includes WWAN)</li> </ul>	579614-001
	For use with Compaq models only	
	<ul style="list-style-type: none"> <li>10.1-inch, high-definition, AntiGlare display assembly</li> </ul>	572414-001
	<ul style="list-style-type: none"> <li>10.1-inch, standard-definition, AntiGlare display assembly (includes WWAN)</li> </ul>	571417-001
	<ul style="list-style-type: none"> <li>10.1-inch, standard-definition, AntiGlare display assembly</li> </ul>	537643-001
	<ul style="list-style-type: none"> <li>10.1-inch, WSVGA, AntiGlare display assembly (includes WWAN)</li> </ul>	579626-001
<b>(2)</b>	<b>Keyboard</b>	
	For use only on black and blue models with Windows operating system installed	
	<ul style="list-style-type: none"> <li>For use only in Brazil</li> </ul>	535689-201
	<ul style="list-style-type: none"> <li>For use only in the Czech Republic</li> </ul>	535689-221
	<ul style="list-style-type: none"> <li>For use only in Europe</li> </ul>	535689-A41
	<ul style="list-style-type: none"> <li>For use only in Finland, Norway, and Sweden</li> </ul>	535689-DH1
	<ul style="list-style-type: none"> <li>For use only in France</li> </ul>	535689-051
	<ul style="list-style-type: none"> <li>For use only in French Canada</li> </ul>	535689-121
	<ul style="list-style-type: none"> <li>For use only in Germany</li> </ul>	535689-041
	<ul style="list-style-type: none"> <li>For use only in Greece</li> </ul>	535689-151
	<ul style="list-style-type: none"> <li>For use only in Hungary</li> </ul>	535689-211

Item	Description	Spare part number
	• For use with international models	535689-B31
	• For use only in Israel	535689-BB1
	• For use only in Italy	535689-061
	• For use only in Japan	535689-291
	• For use only in Latin America	535689-161
	• For use only in Portugal	535689-131
	• For use only in Russia	535689-251
	• For use only in Saudi Arabia	535689-171
	• For use only in South Korea	535689-AD1
	• For use only in Spain	535689-071
	• For use only in Switzerland	535689-111
	• For use only in Taiwan	535689-AB1
	• For use only in Thailand	535689-281
	• For use only in Turkey	535689-141
	• For use only in the United Kingdom	535689-031
	• For use only in the United States	535689-001
	For use only on models with Mobile Mi installed	
	• For use only in Brazil	535690-201
	• For use only in French Canada	535690-121
	• For use only in Japan	535690-291
	• For use only in Latin America	535690-161
	• For use only in South Korea	535690-AD1
	• For use only in Taiwan	535690-AB1
	• For use only in Thailand	535690-281
	• For use only in the United States	535690-001
	For use on pink models only	
	• For use only in Bosnia, Croatia, Montenegro, Serbia, and Slovenia	537954-BA1
	• For use only in Brazil	537954-201
	• For use only in the Czech Republic	537954-221
	• For use only in Europe	537954-A41
	• For use only in Finland, Norway, and Sweden	537954-DH1
	• For use only in France	537954-051
	• For use only in French Canada	537954-121
	• For use only in Germany	537954-041

<b>Item</b>	<b>Description</b>	<b>Spare part number</b>
	• For use only in Greece	537954-DJ1
	• For use only in Hungary	537954-211
	• For use with international models	537954-B31
	• For use only in Israel	537954-BB1
	• For use only in Italy	537954-061
	• For use only in Japan	537954-291
	• For use only in Latin America	537954-161
	• For use only in Portugal	537954-131
	• For use only in Russia	537954-251
	• For use only in Saudi Arabia	537954-171
	• For use only in South Korea	537954-AD1
	• For use only in Spain	537954-071
	• For use only in Switzerland	537954-BG1
	• For use only in Taiwan	537954-AB1
	• For use only in Thailand	537954-281
	• For use only in Turkey	537954-141
	• For use only in the United Kingdom	537954-031
	• For use in the United States only	537954-001
	For use with white HP models only	
	• For use only in Bosnia, Croatia, Montenegro, Serbia, and Slovenia	537953-BA1
	• For use only in Brazil	537953-201
	• For use only in the Czech Republic	537953-221
	• For use only in Europe	537953-A41
	• For use only in Finland, Norway, and Sweden	537953-DH1
	• For use only in France	537953-051
	• For use only in French Canada	537953-121
	• For use only in Germany	537953-041
	• For use only in Greece	537953-DJ1
	• For use only in Hungary	537953-211
	• For use with international models	537953-B31
	• For use only in Israel	537953-BB1
	• For use only in Italy	537953-061
	• For use only in Japan	537953-291
	• For use only in Latin America	537953-161

Item	Description	Spare part number
	<ul style="list-style-type: none"> <li>For use only in Portugal</li> </ul>	537953-131
	<ul style="list-style-type: none"> <li>For use only in Russia</li> </ul>	537953-251
	<ul style="list-style-type: none"> <li>For use only in Saudi Arabia</li> </ul>	537953-171
	<ul style="list-style-type: none"> <li>For use only in South Korea</li> </ul>	537953-AD1
	<ul style="list-style-type: none"> <li>For use only in Spain</li> </ul>	537953-071
	<ul style="list-style-type: none"> <li>For use only in Switzerland</li> </ul>	537953-BG1
	<ul style="list-style-type: none"> <li>For use only in Taiwan</li> </ul>	537953-AB1
	<ul style="list-style-type: none"> <li>For use only in Thailand</li> </ul>	537953-281
	<ul style="list-style-type: none"> <li>For use only in Turkey</li> </ul>	537953-141
	<ul style="list-style-type: none"> <li>For use only in the United Kingdom</li> </ul>	537953-031
	For use only with white HP and HP Mini 110 by Studio Tord Boontje models in the United States	537953-001
<b>(3)</b>	<b>Top cover</b> (includes TouchPad)	
	<ul style="list-style-type: none"> <li>For use with black and blue models only</li> </ul>	537622-001
	<ul style="list-style-type: none"> <li>For use with pink HP models only</li> </ul>	537625-001
	<ul style="list-style-type: none"> <li>For use with white HP models only</li> </ul>	537624-001
	<ul style="list-style-type: none"> <li>For use with HP Mini 110 by Studio Tord Boontje models only</li> </ul>	579615-001
	<b>Mass storage devices</b>	
	<b>NOTE:</b> Each hard drive spare part kit and solid-state drive spare part kit includes a bracket and screws.	
<b>(4a)</b>	Hard drive (select models only)	
	See <a href="#">Mass storage devices on page 27</a> for a comprehensive list of hard drive spare parts.	
<b>(4b)</b>	Solid-state drive	
	See <a href="#">Mass storage devices on page 27</a> for a comprehensive list of solid-state drive spare parts.	
<b>(5)</b>	<b>Heat sink assembly</b> (includes replacement thermal material)	537619-001
<b>(6)</b>	<b>Fan</b>	537613-001
<b>(7)</b>	<b>USB/audio board</b> (includes cable)	
	For use on the following model numbers only: HP: 110-1000 — 110-1099 and Compaq: 110c-1000 — 110-1099	537614-001
	For use on the following model numbers only: HP: 110-1100 — 110-1199 and Compaq: 110c-1100 — 110-1199	581325-001
<b>(8)</b>	<b>Power/battery pass-through board</b>	
	For use on the following model numbers only: HP: 110-1000 — 110-1099 and Compaq: 110c-1000 — 110-1099	537615-001
	For use on the following model numbers only: HP: 110-1100 — 110-1199 and Compaq: 110c-1100 — 110-1199	581326-001
	<b>Plastics/actuator Kit</b>	537612-001

Item	Description	Spare part number
(9a)	Power switch and wireless switch actuators	
(9b)	Memory module compartment cover	
(9c)	Bezel for Digital Media Slot (consumer models) or Media Card Reader (commercial models)	
<b>Wireless modules</b>		
(10)	<b>WLAN module</b>	
	WLAN/Bluetooth combination module	575920-001
	Broadcom 4312 802.11/b/g/n WLAN module	
	<ul style="list-style-type: none"> <li>For use in Canada, the Cayman Islands, Guam, Puerto Rico, the U.S. Virgin Islands, and the United States</li> </ul>	518436-001
	<ul style="list-style-type: none"> <li>For use in Afghanistan, Albania, Algeria, Andorra, Angola, Antigua and Barbuda, Argentina, Armenia, Aruba, Australia, Austria, Azerbaijan, the Bahamas, Bahrain, Bangladesh, Barbados, Belarus, Belgium, Belize, Benin, Bermuda, Bhutan, Bolivia, Bosnia and Herzegovina, Botswana, Brazil, the British Virgin Islands, Brunei, Bulgaria, Burkina Faso, Burundi, Cameroon, Cape Verde, the Central African Republic, Chad, Chile, Colombia, Comoros, the Congo, Costa Rica, Croatia, Cyprus, the Czech Republic, Denmark, Djibouti, Dominica, the Dominican Republic, East Timor, Ecuador, Egypt, El Salvador, Equatorial Guinea, Eritrea, Estonia, Ethiopia, Fiji, Finland, France, French Guiana, Gabon, Gambia, Georgia, Germany, Ghana, Gibraltar, Greece, Grenada, Guadeloupe, Guatemala, Guinea, Guinea-Bissau, Guyana, Haiti, Honduras, Hong Kong, Hungary, Iceland, India, Ireland, Israel, Italy, the Ivory Coast, Jamaica, Jordan, Kazakhstan, Kenya, Kiribati, Kyrgyzstan, Laos, Latvia, Lebanon, Lesotho, Liberia, Liechtenstein, Lithuania, Luxembourg, Macedonia, Madagascar, Malawi, Malaysia, the Maldives, Mali, Malta, the Marshall Islands, Martinique, Mauritania, Mauritius, Mexico, Micronesia, Monaco, Mongolia, Montenegro, Morocco, Mozambique, Namibia, Nauru, Nepal, the Nether Antilles, the Netherlands, New Zealand, Nicaragua, Niger, Nigeria, Norway, Oman, Pakistan, Palau, Panama, Papua New Guinea, Paraguay, the People's Republic of China, Peru, the Philippines, Poland, Portugal, the Republic of Moldova, Romania, Russia, Rwanda, Samoa, San Marino, Sao Tome and Principe, Saudi Arabia, Senegal, Serbia, the Seychelles, Sierra Leone, Singapore, Slovakia, Slovenia, the Solomon Islands, Somalia, South Africa, South Korea, Spain, Sri Lanka, St. Kitts and Nevis, St. Lucia, St. Vincent and the Grenadines, Suriname, Swaziland, Sweden, Switzerland, Taiwan, Tajikistan, Tanzania, Togo, Tonga, Trinidad and Tobago, Tunisia, Turkey, Turkmenistan, Tuvalu, Uganda, Ukraine, the United Arab Emirates, the United Kingdom, Uruguay, Uzbekistan, Vanuatu, Venezuela, Vietnam, Yemen, Zaire, Zambia, and Zimbabwe</li> </ul>	518436-002
	Broadcom 4312 802.11/b/g WLAN module	
	<ul style="list-style-type: none"> <li>For use in Canada, the Cayman Islands, Guam, Puerto Rico, the U.S. Virgin Islands, and the United States</li> </ul>	504593-003



Item	Description	Spare part number
	<ul style="list-style-type: none"> <li>For use in Afghanistan, Albania, Algeria, Andorra, Angola, Antigua and Barbuda, Argentina, Armenia, Aruba, Australia, Austria, Azerbaijan, the Bahamas, Bahrain, Bangladesh, Barbados, Belarus, Belgium, Belize, Benin, Bermuda, Bhutan, Bolivia, Bosnia and Herzegovina, Botswana, Brazil, the British Virgin Islands, Brunei, Bulgaria, Burkina Faso, Burundi, Cameroon, Cape Verde, the Central African Republic, Chad, Chile, Colombia, Comoros, the Congo, Costa Rica, Croatia, Cyprus, the Czech Republic, Denmark, Djibouti, Dominica, the Dominican Republic, East Timor, Ecuador, Egypt, El Salvador, Equatorial Guinea, Eritrea, Estonia, Ethiopia, Fiji, Finland, France, French Guiana, Gabon, Gambia, Georgia, Germany, Ghana, Gibraltar, Greece, Grenada, Guadeloupe, Guatemala, Guinea, Guinea-Bissau, Guyana, Haiti, Honduras, Hong Kong, Hungary, Iceland, India, Ireland, Israel, Italy, the Ivory Coast, Jamaica, Jordan, Kazakhstan, Kenya, Kiribati, Kyrgyzstan, Laos, Latvia, Lebanon, Lesotho, Liberia, Liechtenstein, Lithuania, Luxembourg, Macedonia, Madagascar, Malawi, Malaysia, the Maldives, Mali, Malta, the Marshall Islands, Martinique, Mauritania, Mauritius, Mexico, Micronesia, Monaco, Mongolia, Montenegro, Morocco, Mozambique, Namibia, Nauru, Nepal, the Nether Antilles, the Netherlands, New Zealand, Nicaragua, Niger, Nigeria, Norway, Oman, Pakistan, Palau, Panama, Papua New Guinea, Paraguay, the People's Republic of China, Peru, the Philippines, Poland, Portugal, the Republic of Moldova, Romania, Russia, Rwanda, Samoa, San Marino, Sao Tome and Principe, Saudi Arabia, Senegal, Serbia, the Seychelles, Sierra Leone, Singapore, Slovakia, Slovenia, the Solomon Islands, Somalia, South Africa, South Korea, Spain, Sri Lanka, St. Kitts and Nevis, St. Lucia, St. Vincent and the Grenadines, Suriname, Swaziland, Sweden, Switzerland, Taiwan, Tajikistan, Tanzania, Togo, Tonga, Trinidad and Tobago, Tunisia, Turkey, Turkmenistan, Tuvalu, Uganda, Ukraine, the United Arab Emirates, the United Kingdom, Uruguay, Uzbekistan, Vanuatu, Venezuela, Vietnam, Yemen, Zaire, Zambia, and Zimbabwe</li> </ul>	504593-004
<b>(11)</b>	<b>WWAN module</b>	
	<b>NOTE:</b> Not available for computers with Mobile Mi installed.	
	HP un2400 Mobile Broadband Module (select models only)	483377-002
	HP un2400 Mobile Broadband Module for use only with Verizon Wireless (select models only)	483377-003
	WWAN module for use only in the People's Republic of China	571888-001
	HP un2400 Mobile Broadband Module for use only in the People's Republic of China	574246-001
	WWAN minicard module	531993-001
	WWAN module for use only with Telefonica	592625-161
	WWAN module for use only with Am Movil	592624-161
	WWAN module for use only with AT&T	591612-001
<b>(12)</b>	<b>RTC battery</b>	537616-001
<b>(13)</b>	<b>System board</b> (includes processor and replacement thermal material)	
	Includes Intel Atom N280 1.66-GHz processor, 512-KB Level 2 cache, 533-MHz front-side bus (FSB)	571370-001
	For use on the following model numbers only: HP: 110-1000 — 110-1099 and Compaq: 110c-1000 — 110-1099	
	Includes Intel Atom N270 1.6-GHz processor, 512-KB Level 2 cache, 533-MHz front-side bus (FSB)	537662-001
	For use on the following model numbers only: HP: 110-1000 — 110-1099 and Compaq: 110c-1000 — 110-1099	

Item	Description	Spare part number
	Includes Intel Atom N280 1.66-GHz processor, 512-KB Level 2 cache, 533-MHz front-side bus (FSB)  For use on the following model numbers only: HP: 110-1100 — 110-1199 and Compaq: 110c-1100 — 110-1199	579569-001
	Includes Intel Atom N270 1.6-GHz processor, 512-KB Level 2 cache, 533-MHz front-side bus (FSB)  For use on the following model numbers only: HP: 110-1100 — 110-1199 and Compaq: 110c-1100 — 110-1199	579568-001
<b>(14)</b>	<b>Memory module</b> (PC2-5300, 533-MHz, DDR2)	
	512-MB (for use in HP Mini 110 and Compaq Mini 110 models only)	537663-001
	1024-MB	537664-001
	2048-MB	537665-001
<b>(15)</b>	<b>Base enclosure</b> (includes 4 rubber feet)	
	For use with black and blue models only	537611-001
	For use with pink, white, and HP Mini 110 by Studio Tord Boontje models only	591650-001
<b>(16)</b>	<b>Battery</b>	
	6-cell lithium-polymer (Li-Pol) battery (2.55-Ah, 55-Wh)	537627-001
	3-cell lithium-polymer (Li-Pol) battery (2.55-Ah, 28-Wh)	537626-001

## Display assembly components

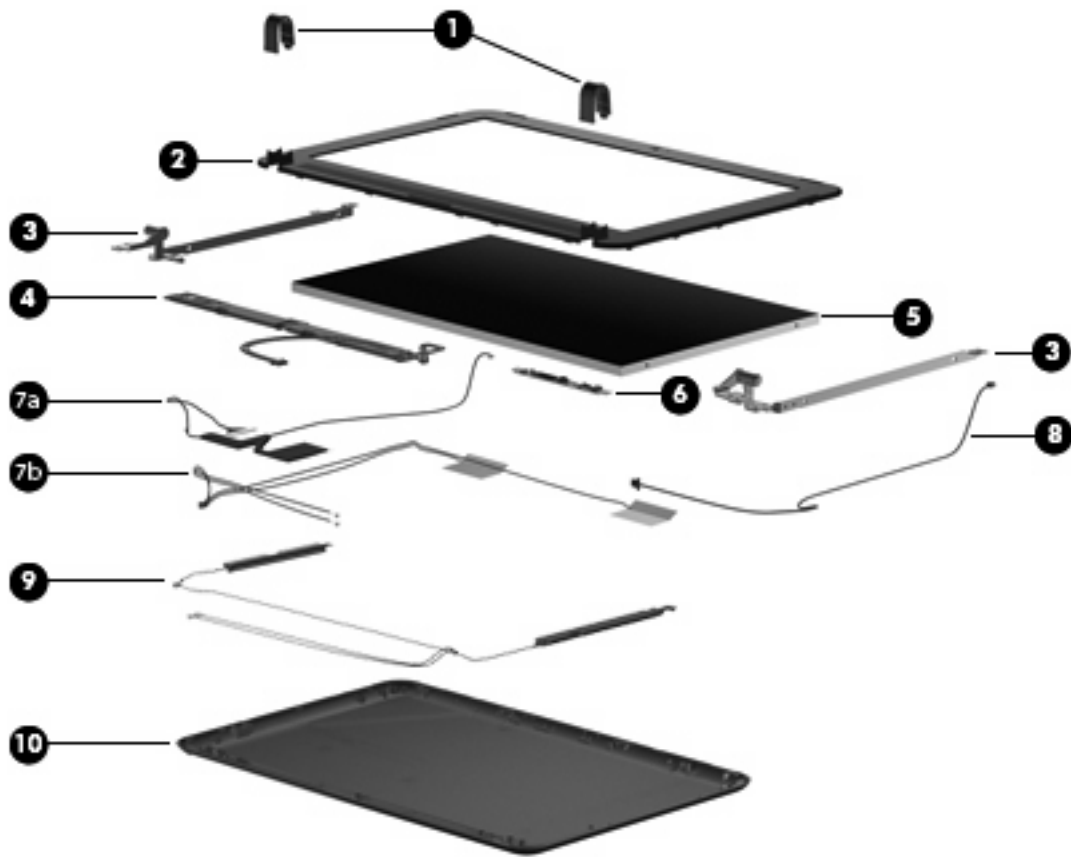

Item	Description	Spare part number
(1)	<b>Hinge covers</b>	537617-001
(2)	<b>Display bezel</b>	
	For use with HP Mini 1101 and HP Mini 110 only	537650-001
	For use with HP Mini 110 by Studio Tord Boontje models only	581324-001
	For use with Compaq Mini 110 only	537644-001
(3)	<b>Display Hinge Kit</b>	537658-001
	(Includes left and right display panel hinges)	
(4)	<b>Speaker assembly</b> (includes left and right cables)	537621-001
(5)	<b>Display panel</b>	
	10.1-inch high-definition AntiGlare	572405-001
	10.1-inch standard-definition AntiGlare	537656-001
	10.1-inch WSVGA AntiGlare	579570-001
(6)	<b>Webcam module</b>	537660-001
	<b>Display Cable Kit</b> (not illustrated, includes display/webcam cable and WLAN antennas)	
(7a)	Display panel cable	

<b>Item</b>	<b>Description</b>	<b>Spare part number</b>
<b>(7b)</b>	WLAN antennas	
	<ul style="list-style-type: none"> <li>For use with high-definition and standard-definition display panels only</li> </ul>	537657-001
	<ul style="list-style-type: none"> <li>For use with WSVGA display panels only</li> </ul>	579571-001
<b>(8)</b>	Microphone assembly	581323-001
<b>(9)</b>	WWAN antennas (not available on computers with Mobile Mi installed.)	537655-001
<b>(10)</b>	<b>Display enclosure</b> (includes logo)	
	For use with black HP models only	537651-001
	For use with pink HP models only	537654-001
	For use with white HP models only	537653-001
	For use with blue HP models only	591649-001
	For use with HP Mini 110 by Studio Tord Boontje models only	579576-001
	For use with Compaq models only	537645-001
	<b>Display Screw Kit</b> (not illustrated)	538510-001

## Mass storage devices

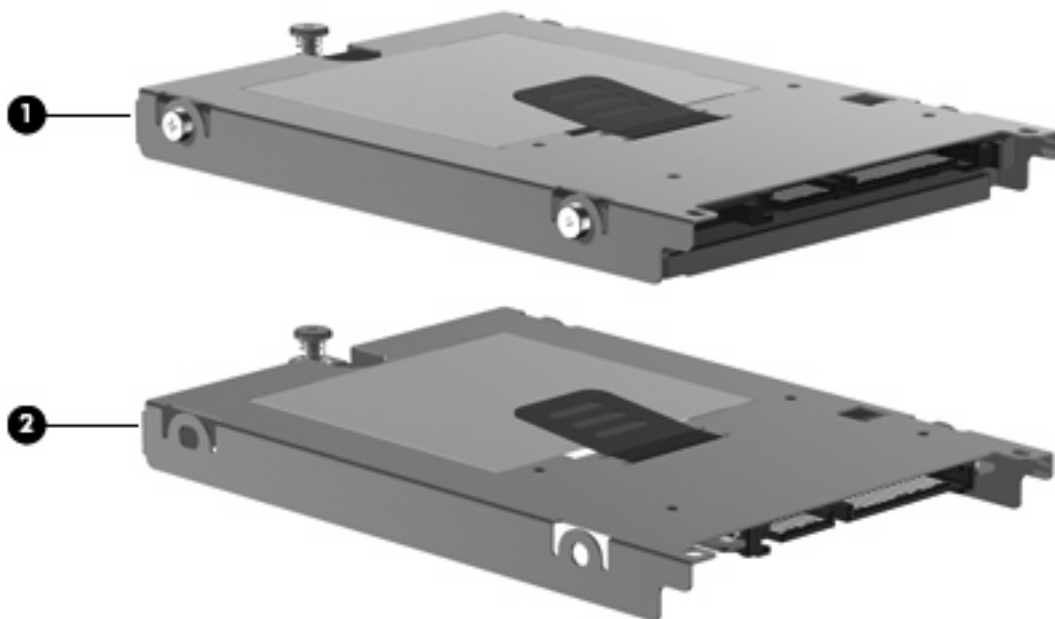

 **NOTE:** Each hard drive spare part kit and solid-state drive spare part kit includes a cable and bracket.

Item	Description	Spare part number
(1)	Hard drive (select models only)	
	320-GB, 5400-RPM	591398-001
	250-GB, 5400-RPM	537635-001
	160-GB, 7200-RPM	590669-001
	160-GB, 5400-RPM	537634-001
	Hard Drive Hardware Kit (not illustrated)	537641-001
(2)	Solid-state drive	
	64-GB	537640-001
	32-GB	537639-001
	16-GB	537638-001
	8-GB	537637-001
	Solid-state Drive Hardware Kit (not illustrated)	537642-001

## Miscellaneous parts

Description	Spare part number
<b>30-W UMA AC adapter</b>	496813-001
<b>Bluetooth® adapter</b>	574670-001
<b>High-definition video decoder</b>	578237-001
<b>Power cords</b>	
For use in Argentina	490371-D01
For use in Australia	490371-011
For use in Brazil	490371-201
For use in Denmark	490371-081
For use in Europe	490371-021
For use in India	490371-D61
For use in Israel	490371-BB1
For use in Italy	490371-061
For use in Japan	490371-291
For use in North America	490371-001
For use in the People's Republic of China	490371-AA1
For use in Singapore and the United Kingdom	490371-031
For use in South Africa	490371-AR1
For use in South Korea	490371-AD1
For use in Switzerland	490371-111
For use in Taiwan	490371-AB1
<b>Rubber Kit</b> (contains 4 device feet)	
For use with black and blue models only	537618-001
For use with pink, white, and HP Mini 110 by Studio Tord Boontje models only	537618-002
<b>Screw Kit</b>	537620-001

## Sequential part number listing

Spare part number	Description
483377-002	HP un2400 Mobile Broadband Module (select models only)
483377-003	HP un2400 Mobile Broadband Module for use with Verizon Wireless only (select models only)
490371-001	Power cord for use in North America
490371-011	Power cord for use in Australia
490371-021	Power cord for use in Europe
490371-031	Power cord for use in Singapore and the United Kingdom
490371-061	Power cord for use in Italy
490371-081	Power cord for use in Denmark
490371-111	Power cord for use in Switzerland
490371-201	Power cord for use in Brazil
490371-291	Power cord for use in Japan
490371-AA1	Power cord for use in the People's Republic of China
490371-AB1	Power cord for use in Taiwan
490371-AD1	Power cord for use in South Korea
490371-AR1	Power cord for use in South Africa
490371-BB1	Power cord for use in Israel
490371-D01	Power cord for use in Argentina
490371-D61	Power cord for use in India
496813-001	30-W UMA AC adapter
504593-003	Broadcom 4312 802.11/b/g WLAN module for use in Canada, the Cayman Islands, Guam, Puerto Rico, the U.S. Virgin Islands, and the United States
504593-004	Broadcom 4312 802.11/b/g WLAN module for use in Afghanistan, Albania, Algeria, Andorra, Angola, Antigua and Barbuda, Argentina, Armenia, Aruba, Australia, Austria, Azerbaijan, the Bahamas, Bahrain, Bangladesh, Barbados, Belarus, Belgium, Belize, Benin, Bermuda, Bhutan, Bolivia, Bosnia and Herzegovina, Botswana, Brazil, the British Virgin Islands, Brunei, Bulgaria, Burkina Faso, Burundi, Cameroon, Cape Verde, the Central African Republic, Chad, Chile, Colombia, Comoros, the Congo, Costa Rica, Croatia, Cyprus, the Czech Republic, Denmark, Djibouti, Dominica, the Dominican Republic, East Timor, Ecuador, Egypt, El Salvador, Equatorial Guinea, Eritrea, Estonia, Ethiopia, Fiji, Finland, France, French Guiana, Gabon, Gambia, Georgia, Germany, Ghana, Gibraltar, Greece, Grenada, Guadeloupe, Guatemala, Guinea, Guinea-Bissau, Guyana, Haiti, Honduras, Hong Kong, Hungary, Iceland, India, Ireland, Israel, Italy, the Ivory Coast, Jamaica, Jordan, Kazakhstan, Kenya, Kiribati, Kyrgyzstan, Laos, Latvia, Lebanon, Lesotho, Liberia, Liechtenstein, Lithuania, Luxembourg, Macedonia, Madagascar, Malawi, Malaysia, the Maldives, Mali, Malta, the Marshall Islands, Martinique, Mauritania, Mauritius, Mexico, Micronesia, Monaco, Mongolia, Montenegro, Morocco, Mozambique, Namibia, Nauru, Nepal, the Nether Antilles, the Netherlands, New Zealand, Nicaragua, Niger, Nigeria, Norway, Oman, Pakistan, Palau, Panama, Papua New Guinea, Paraguay, the People's Republic of China, Peru, the Philippines, Poland, Portugal, the Republic of Moldova, Romania, Russia, Rwanda, Samoa, San Marino, Sao Tome and Principe, Saudi Arabia, Senegal, Serbia, the Seychelles, Sierra Leone, Singapore, Slovakia, Slovenia, the Solomon Islands, Somalia, South Africa, South Korea, Spain, Sri Lanka, St. Kitts and Nevis, St. Lucia, St. Vincent and the Grenadines, Suriname, Swaziland, Sweden, Switzerland, Taiwan, Tajikistan, Tanzania, Togo, Tonga, Trinidad and Tobago, Tunisia, Turkey, Turkmenistan, Tuvalu, Uganda, Ukraine, the United Arab Emirates, the United Kingdom, Uruguay, Uzbekistan, Vanuatu, Venezuela, Vietnam, Yemen, Zaire, Zambia, and Zimbabwe

<b>Spare part number</b>	<b>Description</b>
518436-001	Broadcom 4312 802.11/b/g/n WLAN module for use in Canada, the Cayman Islands, Guam, Puerto Rico, the U.S. Virgin Islands, and the United States
518436-002	Broadcom 4312 802.11/b/g/n WLAN module for use in Afghanistan, Albania, Algeria, Andorra, Angola, Antigua and Barbuda, Argentina, Armenia, Aruba, Australia, Austria, Azerbaijan, the Bahamas, Bahrain, Bangladesh, Barbados, Belarus, Belgium, Belize, Benin, Bermuda, Bhutan, Bolivia, Bosnia and Herzegovina, Botswana, Brazil, the British Virgin Islands, Brunei, Bulgaria, Burkina Faso, Burundi, Cameroon, Cape Verde, the Central African Republic, Chad, Chile, the People's Republic of China, Colombia, Comoros, the Congo, Costa Rica, Croatia, Cyprus, the Czech Republic, Denmark, Djibouti, Dominica, the Dominican Republic, East Timor, Ecuador, Egypt, El Salvador, Equatorial Guinea, Eritrea, Estonia, Ethiopia, Fiji, Finland, France, French Guiana, Gabon, Gambia, Georgia, Germany, Ghana, Gibraltar, Greece, Grenada, Guadeloupe, Guatemala, Guinea, Guinea-Bissau, Guyana, Haiti, Honduras, Hong Kong, Hungary, Iceland, India, Ireland, Israel, Italy, the Ivory Coast, Jamaica, Jordan, Kazakhstan, Kenya, Kiribati, Kyrgyzstan, Laos, Latvia, Lebanon, Lesotho, Liberia, Liechtenstein, Lithuania, Luxembourg, Macedonia, Madagascar, Malawi, Malaysia, the Maldives, Mali, Malta, the Marshall Islands, Martinique, Mauritania, Mauritius, Mexico, Micronesia, Monaco, Mongolia, Montenegro, Morocco, Mozambique, Namibia, Nauru, Nepal, the Nether Antilles, the Netherlands, New Zealand, Nicaragua, Niger, Nigeria, Norway, Oman, Pakistan, Palau, Panama, Papua New Guinea, Paraguay, Peru, the Philippines, Poland, Portugal, the Republic of Moldova, Romania, Russia, Rwanda, Samoa, San Marino, Sao Tome and Principe, Saudi Arabia, Senegal, Serbia, the Seychelles, Sierra Leone, Singapore, Slovakia, Slovenia, the Solomon Islands, Somalia, South Africa, South Korea, Spain, Sri Lanka, St. Kitts and Nevis, St. Lucia, St. Vincent and the Grenadines, Suriname, Swaziland, Sweden, Switzerland, Taiwan, Tajikistan, Tanzania, Togo, Tonga, Trinidad and Tobago, Tunisia, Turkey, Turkmenistan, Tuvalu, Uganda, Ukraine, the United Arab Emirates, the United Kingdom, Uruguay, Uzbekistan, Vanuatu, Venezuela, Vietnam, Yemen, Zaire, Zambia, and Zimbabwe
531993-001	WWAN minicard module
535689-001	Keyboard for use only in the United States on black and blue models with Windows operating system installed
535689-031	Keyboard for use only in the United Kingdom on black and blue models with Windows operating system installed
535689-041	Keyboard for use only in Germany on black and blue models with Windows operating system installed
535689-051	Keyboard for use only in France on black and blue models with Windows operating system installed
535689-061	Keyboard for use only in Italy on black and blue models with Windows operating system installed
535689-071	Keyboard for use only in Spain on black and blue models with Windows operating system installed
535689-121	Keyboard for use only in French Canada on black and blue models with Windows operating system installed
535689-131	Keyboard for use only in Portugal on black and blue models with Windows operating system installed
535689-141	Keyboard for use only in Turkey on black and blue models with Windows operating system installed
535689-151	Keyboard for use only in Greece on black and blue models with Windows operating system installed
535689-161	Keyboard for use only in Latin America on black and blue models with Windows operating system installed
535689-171	Keyboard for use only in Saudi Arabia on black and blue models with Windows operating system installed
535689-201	Keyboard for use only in Brazil on black and blue models with Windows operating system installed
535689-211	Keyboard for use only in Hungary on black and blue models with Windows operating system installed
535689-221	Keyboard for use only in the Czech Republic on black and blue models with Windows operating system installed
535689-251	Keyboard for use only in Russia on black and blue models with Windows operating system installed
535689-281	Keyboard for use only in Thailand on black and blue models with Windows operating system installed
535689-291	Keyboard for use only in Japan on black and blue models with Windows operating system installed



<b>Spare part number</b>	<b>Description</b>
535689-A41	Keyboard for use only in Europe on black and blue models with Windows operating system installed
535689-AB1	Keyboard for use only in Taiwan on black and blue models with Windows operating system installed
535689-AD1	Keyboard for use only in South Korea on black and blue models with Windows operating system installed
535689-B31	Keyboard for use only with international models on black and blue models with Windows operating system installed
535689-BB1	Keyboard for use only in Israel on black and blue models with Windows operating system installed
535689-DH1	Keyboard for use only in Finland, Norway and Sweden on black and blue models with Windows operating system installed
535690-001	Keyboard for use only in the United States on models with Mobile Mi installed
535690-121	Keyboard for use only in French Canada on models with Mobile Mi installed
535690-161	Keyboard for use only in Latin America on models with Mobile Mi installed
535690-201	Keyboard for use only in Brazil on models with Mobile Mi installed
535690-281	Keyboard for use only in Thailand on models with Mobile Mi installed
535690-291	Keyboard for use only in Japan on models with Mobile Mi installed
535690-AB1	Keyboard for use only in Taiwan on models with Mobile Mi installed
535690-AD1	Keyboard for use only in South Korea on models with Mobile Mi installed
537611-001	Base enclosure for use on black and blue models only (includes 4 rubber feet)
537612-001	Plastics/actuator Kit (includes power switch and wireless switch actuators, memory module compartment cover, and bezel for Digital Media Slot (consumer models) or Media Card Reader (commercial models))
537613-001	Fan
537614-001	USB/audio board (includes cable) for use on the following model numbers only: HP: 110-1000 — 110-1099 and Compaq: 110c-1000 — 110-1099
537615-001	Power/battery pass-through board for use on the following model numbers only: HP: 110-1000 — 110-1099 and Compaq: 110c-1000 — 110-1099
537616-001	RTC battery
537617-001	Display assembly hinge covers
537618-001	Rubber Kit for use with black and blue models only (contains 4 device feet)
537618-002	Rubber Kit for use with pink, white, and HP Mini 110 by Studio Tord Boontje models only (contains 4 device feet)
537619-001	Heat sink assembly (includes replacement thermal material)
537620-001	Screw Kit
537621-001	Speaker assembly (includes left and right cables)
537622-001	Top cover for use on black and blue models only (includes TouchPad)
537624-001	Top cover for use on white HP models only (includes TouchPad)
537625-001	Top cover for use on pink HP models only (includes TouchPad)
537626-001	3-cell lithium-polymer (Li-Pol) battery (2.55-Ah, 28-Wh)

<b>Spare part number</b>	<b>Description</b>
537627-001	6-cell lithium-polymer (Li-Pol) battery (2.55-Ah, 55-Wh)
537634-001	160-GB hard drive, 5400-RPM
537635-001	250-GB hard drive, 5400-RPM
537637-001	8-GB solid-state drive
537638-001	16-GB solid-state drive
537639-001	32-GB solid-state drive
537640-001	64-GB solid-state drive
537641-001	Hard Drive Hardware Kit
537642-001	Solid-state Drive Hardware Kit
537643-001	10.1-inch, standard-definition, AntiGlare display assembly for use with Compaq models only (includes 1 webcam, 1 microphone, 1 speaker box, and 2 WLAN antenna transceivers/cables)
537644-001	Display bezel for use with Compaq models only
537645-001	Display enclosure (includes logo) for use with Compaq models only
537646-001	10.1-inch, standard-definition, AntiGlare display assembly for use with black HP models only (includes 1 webcam, 1 microphone, 1 speaker box, and 2 WLAN antenna transceivers/cables)
537650-001	Display bezel for use with HP Mini 1101 and HP Mini 110 only
537651-001	Display enclosure (includes logo) for use with black HP models only
537653-001	Display enclosure (includes logo) for use with white HP models only
537654-001	Display enclosure (includes logo) for use with pink HP models only
537655-001	WWAN antennas (not available on computers with Mobile Mi installed)
537656-001	10.1-inch standard-definition AntiGlare display panel
537657-001	Display Cable Kit for use with high-definition and standard-definition display panels only (includes display panel/webcam cable and WLAN antennas)
537658-001	Display Hinge Kit (includes left and right display panel hinges)
537660-001	Webcam module
537662-001	System board (includes Intel Atom N270 1.6-GHz processor, 512-KB Level 2 cache, 533-MHz front-side bus (FSB), and thermal replacement material for use on the following model numbers only: HP: 110-1000 — 110-1099 and Compaq: 110c-1000 — 110-1099)
537663-001	512-MB memory module (PC2-5300, 533-MHz, DDR2, for use in HP Mini 110 and Compaq: Mini 110 models only)
537664-001	1024-MB memory module (PC2-5300, 533-MHz, DDR2)
537665-001	2048-MB memory module (PC2-5300, 533-MHz, DDR2)
537953-001	Keyboard for use with white HP and HP Mini 110 by Studio Tord Boontje models only in the United States
537953-031	Keyboard for use with white HP models only in the United Kingdom
537953-041	Keyboard for use with white HP models only in Germany
537953-051	Keyboard for use with white HP models only in France

<b>Spare part number</b>	<b>Description</b>
537953-061	Keyboard for use with white HP models only in Italy
537953-071	Keyboard for use with white HP models only in Spain
537953-121	Keyboard for use with white HP models only in French Canada
537953-131	Keyboard for use with white HP models only in Portugal
537953-141	Keyboard for use with white HP models only in Turkey
537953-161	Keyboard for use with white HP models only in Latin America
537953-171	Keyboard for use with white HP models only in Saudi Arabia
537953-201	Keyboard for use with white HP models only in Brazil
537953-211	Keyboard for use with white HP models only in Hungary
537953-221	Keyboard for use with white HP models only in the Czech Republic
537953-251	Keyboard for use with white HP models only in Russia
537953-281	Keyboard for use with white HP models only in Thailand
537953-291	Keyboard for use with white HP models only in Japan
537953-A41	Keyboard for use with white HP models only in Europe
537953-AB1	Keyboard for use with white HP models only in Taiwan
537953-AD1	Keyboard for use with white HP models only in South Korea
537953-B31	Keyboard for use with white HP models with international models
537953-BA1	Keyboard for use with white HP models only in Bosnia, Croatia, Montenegro, Serbia, and Slovenia
537953-BB1	Keyboard for use with white HP models only in Israel
537953-BG1	Keyboard for use with white HP models only in Switzerland
537953-DH1	Keyboard for use with white HP models only in Finland, Norway, and Sweden
537953-DJ1	Keyboard for use with white HP models only in Greece
537954-001	Keyboard for use with pink HP models only in the United States
537954-031	Keyboard for use with pink HP models only in the United Kingdom
537954-041	Keyboard for use with pink HP models only in Germany
537954-051	Keyboard for use with pink HP models only in France
537954-061	Keyboard for use with pink HP models only in Italy
537954-071	Keyboard for use with pink HP models only in Spain
537954-121	Keyboard for use with pink HP models only in French Canada
537954-131	Keyboard for use with pink HP models only in Portugal
537954-141	Keyboard for use with pink HP models only in Turkey
537954-161	Keyboard for use with pink HP models only in Latin America
537954-171	Keyboard for use with pink HP models only in Saudi Arabia

<b>Spare part number</b>	<b>Description</b>
537954-201	Keyboard for use with pink HP models only in Brazil
537954-211	Keyboard for use with pink HP models only in Hungary
537954-221	Keyboard for use with pink HP models only in the Czech Republic
537954-251	Keyboard for use with pink HP models only in Russia
537954-281	Keyboard for use with pink HP models only in Thailand
537954-291	Keyboard for use with pink HP models only in Japan
537954-A41	Keyboard for use with pink HP models only in Europe
537954-AB1	Keyboard for use with pink HP models only in Taiwan
537954-AD1	Keyboard for use with pink HP models only in South Korea
537954-B31	Keyboard for use with pink HP models with international models
537954-BA1	Keyboard for use with pink HP models only in Bosnia, Croatia, Montenegro, Serbia, and Slovenia
537954-BB1	Keyboard for use with pink HP models only in Israel
537954-BG1	Keyboard for use with pink HP models only in Switzerland
537954-DH1	Keyboard for use with pink HP models only in Finland, Norway, and Sweden
537954-DJ1	Keyboard for use with pink HP models only in Greece
538510-001	Display Screw Kit
571370-001	System board (includes Intel Atom N280 1.66-GHz processor, 512-KB Level 2 cache, 533-MHz front-side bus (FSB), and replacement thermal material) for use on the following model numbers only: HP: 110-1000 — 110-1099 and Compaq: 110c-1000 — 110-1099
571414-001	10.1-inch, standard-definition, AntiGlare display assembly (includes WWAN) for use with black HP models only (includes 1 webcam, 1 microphone, 1 speaker box, and 2 WLAN antenna transceivers/cables)
571415-001	10.1-inch, standard-definition, AntiGlare display assembly (includes WWAN) for use with white HP models only (includes 1 webcam, 1 microphone, 1 speaker box, and 2 WLAN antenna transceivers/cables)
571416-001	10.1-inch, standard-definition, AntiGlare display assembly (includes WWAN) for use with pink HP models only (includes 1 webcam, 1 microphone, 1 speaker box, and 2 WLAN antenna transceivers/cables)
571417-001	10.1-inch, standard-definition, AntiGlare display assembly (includes WWAN) for use with Compaq models only (includes 1 webcam, 1 microphone, 1 speaker box, and 2 WLAN antenna transceivers/cables)
571888-001	WWAN module for use only in the People's Republic of China
572405-001	10.1-inch high-definition AntiGlare display panel
572406-001	10.1-inch, high-definition, AntiGlare display assembly for use with black HP models only (includes 1 webcam, 1 microphone, 1 speaker box, and 2 WLAN antenna transceivers/cables)
572407-001	10.1-inch, high-definition, AntiGlare display assembly (includes WWAN) for use with black HP models only (includes 1 webcam, 1 microphone, 1 speaker box, and 2 WLAN antenna transceivers/cables)
572411-001	10.1-inch, high-definition, AntiGlare display assembly (includes WWAN) for use with white HP models only (includes 1 webcam, 1 microphone, 1 speaker box, and 2 WLAN antenna transceivers/cables)
572413-001	10.1-inch, high-definition, AntiGlare display assembly (includes WWAN) for use with pink HP models only (includes 1 webcam, 1 microphone, 1 speaker box, and 2 WLAN antenna transceivers/cables)
572414-001	10.1-inch, high-definition, AntiGlare display assembly for use with Compaq models only (includes 1 webcam, 1 microphone, 1 speaker box, and 2 WLAN antenna transceivers/cables)

<b>Spare part number</b>	<b>Description</b>
574246-001	HP un2400 Mobile Broadband Module for use only in the People's Republic of China
574670-001	Bluetooth adapter
575920-001	WLAN/Bluetooth combination module
578237-001	High-definition video decoder
579568-001	System board (includes Intel Atom N270 1.6-GHz processor, 512-KB Level 2 cache, 533-MHz front-side bus (FSB), and thermal replacement material) for use on the following model numbers only: HP: 110-1100 — 110-1199 and Compaq: 110c-1100 — 110-1199
579569-001	System board (includes Intel Atom N280 1.66-GHz processor, 512-KB Level 2 cache, 533-MHz front-side bus (FSB), and replacement thermal material) for use on the following model numbers only: HP: 110-1100 — 110-1199 and Compaq: 110c-1100 — 110-1199
579570-001	10.1-inch WSVGA AntiGlare display panel
579571-001	Display Cable Kit for use with WSVGA panels only (includes display panel/webcam cable and WLAN antennas)
579576-001	Display enclosure (includes logo) for use with HP Mini 110 by Studio Tord Boontje models only
579604-001	10.1-inch, WSVGA, AntiGlare display assembly (includes WWAN) for use with black HP models only (includes 1 webcam, 1 microphone, 1 speaker box, and 2 WLAN antenna transceivers/cables)
579606-001	10.1-inch, WSVGA, AntiGlare display assembly (includes WWAN) for use with white HP models only (includes 1 webcam, 1 microphone, 1 speaker box, and 2 WLAN antenna transceivers/cables)
579608-001	10.1-inch, WSVGA, AntiGlare display assembly (includes WWAN) for use with pink HP models only (includes 1 webcam, 1 microphone, 1 speaker box, and 2 WLAN antenna transceivers/cables)
579610-001	10.1-inch, standard-definition, AntiGlare display assembly (includes WWAN) for use with HP Mini 110 by Studio Tord Boontje models only (includes 1 webcam, 1 microphone, 1 speaker box, and 2 WLAN antenna transceivers/cables)
579612-001	10.1-inch, high-definition, AntiGlare display assembly (includes WWAN) for use with HP Mini 110 by Studio Tord Boontje models only (includes 1 webcam, 1 microphone, 1 speaker box, and 2 WLAN antenna transceivers/cables)
579614-001	10.1-inch, WSVGA, AntiGlare display assembly (includes WWAN) for use with HP Mini 110 by Studio Tord Boontje models only (includes 1 webcam, 1 microphone, 1 speaker box, and 2 WLAN antenna transceivers/cables)
579615-001	Top cover for use with HP Mini 110 by Studio Tord Boontje models only (includes TouchPad)
579626-001	10.1-inch, WSVGA, AntiGlare display assembly (includes WWAN) for use with Compaq models only (includes 1 webcam, 1 microphone, 1 speaker box, and 2 WLAN antenna transceivers/cables)
581323-001	Microphone assembly
581324-001	Display bezel for use with HP Mini 110 by Studio Tord Boontje models only
581325-001	USB/audio board (includes cable) for use on the following model numbers only: HP: 110-1100 — 110-1199 and Compaq: 110c-1100 — 110-1199
581326-001	Power/battery pass-through board for use on the following model numbers only: HP: 110-1100 — 110-1199 and Compaq: 110c-1100 — 110-1199
590669-001	160-GB, hard drive, 7200-RPM
591398-001	320-GB hard drive, 5400-RPM
591612-001	WWAN module for use only with AT&T

Spare part number	Description
591647-001	10.1-inch, high-definition, AntiGlare display assembly (includes WWAN) for use with blue HP models only (includes 1 webcam, 1 microphone, 1 speaker box, and 2 WLAN antenna transceivers/cables)
591648-001	10.1-inch, WSVGA, AntiGlare display assembly (includes WWAN) for use with blue HP models only (includes 1 webcam, 1 microphone, 1 speaker box, and 2 WLAN antenna transceivers/cables)
591649-001	Display enclosure (includes logo) for use with blue HP models only
591650-001	Base enclosure for use on pink, white, and HP Mini 110 by Studio Tord Boontje models only (includes 4 rubber feet)
592624-161	WWAN module for use only with Am Movil
592625-161	WWAN module for use only with Telefonica

---

# 4 Removal and replacement procedures

## Preliminary replacement requirements

### Tools required

You will need the following tools to complete the removal and replacement procedures:

- Flat-bladed screwdriver
- Magnetic screwdriver
- Phillips P0 and P1 screwdrivers

### Service considerations

The following sections include some of the considerations that you must keep in mind during disassembly and assembly procedures.

---

 **NOTE:** As you remove each subassembly from the device, place the subassembly (and all accompanying screws) away from the work area to prevent damage.

---

### Plastic parts

---

△ **CAUTION:** Using excessive force during disassembly and reassembly can damage plastic parts. Use care when handling the plastic parts. Apply pressure only at the points designated in the maintenance instructions.

---

### Cables and connectors

---

△ **CAUTION:** When servicing the device, be sure that cables are placed in their proper locations during the reassembly process. Improper cable placement can damage the device.

---

Cables must be handled with extreme care to avoid damage. Apply only the tension required to unseat or seat the cables during removal and insertion. Handle cables by the connector whenever possible. In all cases, avoid bending, twisting, or tearing cables. Be sure that cables are routed in such a way that they cannot be caught or snagged by parts being removed or replaced. Handle flex cables with extreme care; these cables tear easily.

## Drive handling

△ **CAUTION:** Drives are fragile components that must be handled with care. To prevent damage to the device, damage to a drive, or loss of information, observe these precautions:

Before removing or inserting a hard drive, shut down the device. If you are unsure whether the device is off or in Hibernation, turn the device on, and then shut it down through the operating system.

Before handling a drive, be sure that you are discharged of static electricity. While handling a drive, avoid touching the connector.

Handle drives on surfaces covered with at least one inch of shock-proof foam.

Avoid dropping drives from any height onto any surface.

After removing a hard drive, an optical drive, or a diskette drive, place it in a static-proof bag.

Avoid exposing a hard drive to products that have magnetic fields, such as monitors or speakers.

Avoid exposing a drive to temperature extremes or liquids.

If a drive must be mailed, place the drive in a bubble pack mailer or other suitable form of protective packaging and label the package "FRAGILE."

---



# Grounding guidelines

## Electrostatic discharge damage

Electronic components are sensitive to electrostatic discharge (ESD). Circuitry design and structure determine the degree of sensitivity. Networks built into many integrated circuits provide some protection, but in many cases, ESD contains enough power to alter device parameters or melt silicon junctions.

A discharge of static electricity from a finger or other conductor can destroy static-sensitive devices or microcircuitry. Even if the spark is neither felt nor heard, damage may have occurred.

An electronic device exposed to ESD may not be affected at all and can work perfectly throughout a normal cycle. Or the device may function normally for a while, then degrade in the internal layers, reducing its life expectancy.

△ **CAUTION:** To prevent damage to the device when you are removing or installing internal components, observe these precautions:

Keep components in their electrostatic-safe containers until you are ready to install them.

Use nonmagnetic tools.

Before touching an electronic component, discharge static electricity by using the guidelines described in this section.

Avoid touching pins, leads, and circuitry. Handle electronic components as little as possible.

If you remove a component, place it in an electrostatic-safe container.

The following table shows how humidity affects the electrostatic voltage levels generated by different activities.

△ **CAUTION:** A product can be degraded by as little as 700 V.

Typical electrostatic voltage levels			
Event	Relative humidity		
	10%	40%	55%
Walking across carpet	35,000 V	15,000 V	7,500 V
Walking across vinyl floor	12,000 V	5,000 V	3,000 V
Motions of bench worker	6,000 V	800 V	400 V
Removing DIPS from plastic tube	2,000 V	700 V	400 V
Removing DIPS from vinyl tray	11,500 V	4,000 V	2,000 V
Removing DIPS from Styrofoam	14,500 V	5,000 V	3,500 V
Removing bubble pack from PCB	26,500 V	20,000 V	7,000 V
Packing PCBs in foam-lined box	21,000 V	11,000 V	5,000 V

## Packaging and transporting guidelines

Follow these grounding guidelines when packaging and transporting equipment:

- To avoid hand contact, transport products in static-safe tubes, bags, or boxes.
- Protect ESD-sensitive parts and assemblies with conductive or approved containers or packaging.
- Keep ESD-sensitive parts in their containers until the parts arrive at static-free workstations.
- Place items on a grounded surface before removing items from their containers.
- Always be properly grounded when touching a component or assembly.
- Store reusable ESD-sensitive parts from assemblies in protective packaging or nonconductive foam.
- Use transporters and conveyors made of antistatic belts and roller bushings. Be sure that mechanized equipment used for moving materials is wired to ground and that proper materials are selected to avoid static charging. When grounding is not possible, use an ionizer to dissipate electric charges.

## Workstation guidelines

Follow these grounding workstation guidelines:

- Cover the workstation with approved static-shielding material.
- Use a wrist strap connected to a properly grounded work surface and use properly grounded tools and equipment.
- Use conductive field service tools, such as cutters, screwdrivers, and vacuums.
- When fixtures must directly contact dissipative surfaces, use fixtures made only of static-safe materials.
- Keep the work area free of nonconductive materials, such as ordinary plastic assembly aids and Styrofoam.
- Handle ESD-sensitive components, parts, and assemblies by the case or PCM laminate. Handle these items only at static-free workstations.
- Avoid contact with pins, leads, or circuitry.
- Turn off power and input signals before inserting or removing connectors or test equipment.

## Equipment guidelines

Grounding equipment must include either a wrist strap or a foot strap at a grounded workstation.

- When seated, wear a wrist strap connected to a grounded system. Wrist straps are flexible straps with a minimum of one megohm  $\pm 10\%$  resistance in the ground cords. To provide proper ground, wear a strap snugly against the skin at all times. On grounded mats with banana-plug connectors, use alligator clips to connect a wrist strap.
- When standing, use foot straps and a grounded floor mat. Foot straps (heel, toe, or boot straps) can be used at standing workstations and are compatible with most types of shoes or boots. On conductive floors or dissipative floor mats, use foot straps on both feet with a minimum of one megohm resistance between the operator and ground. To be effective, the conductive strips must be worn in contact with the skin.

The following grounding equipment is recommended to prevent electrostatic damage:

- Antistatic tape
- Antistatic smocks, aprons, and sleeve protectors
- Conductive bins and other assembly or soldering aids
- Nonconductive foam
- Conductive tabletop workstations with ground cords of one megohm resistance
- Static-dissipative tables or floor mats with hard ties to the ground
- Field service kits
- Static awareness labels
- Material-handling packages
- Nonconductive plastic bags, tubes, or boxes
- Metal tote boxes
- Electrostatic voltage levels and protective materials

The following table lists the shielding protection provided by antistatic bags and floor mats.

Material	Use	Voltage protection level
Antistatic plastic	Bags	1,500 V
Carbon-loaded plastic	Floor mats	7,500 V
Metallized laminate	Floor mats	5,000 V

# Component replacement procedures

This chapter provides removal and replacement procedures.

There are as many as 65 screws, in 9 different sizes, that must be removed, replaced, or loosened when servicing the device. Make special note of each screw size and location during removal and replacement.

## Service tag

When ordering parts or requesting information, provide the computer serial number and model description provided on the service tag:

- (1) Product name: This is the product name affixed to the front of the device.
- (2) Serial number (s/n): This is an alphanumeric identifier that is unique to each product.
- (3) Part number/Product number (p/n): This number provides specific information about the product's hardware components. The part number helps a service technician to determine what components and parts are needed.
- (4) Model description: This is the alphanumeric identifier used to locate documents, drivers, and support for the device.
- (5) Warranty period: This number describes the duration of the warranty period for the device.



## Device feet

The device feet are adhesive-backed rubber pads, tethered to the base enclosure.

Description	Spare part number
Rubber Kit	537618-001



## Battery

Description	Spare part number
6-cell lithium-polymer (Li-Pol) battery (2.55-Ah, 55-Wh)	537627-001
3-cell lithium-polymer (Li-Pol) battery (2.55-Ah, 28-Wh)	537626-001

Before disassembling the device, follow these steps:

1. Shut down the device. If you are unsure whether the device is off or in Hibernation, turn the device on, and then shut it down through the operating system.
2. Disconnect all external devices connected to the device.
3. Disconnect the power from the device by first unplugging the power cord from the AC outlet and then unplugging the AC adapter from the device.

Remove the battery:

1. Turn the device upside-down on a flat surface, with the battery bay toward you.
2. Slide the battery release latches (1) to release the battery.
3. Remove the battery (2).

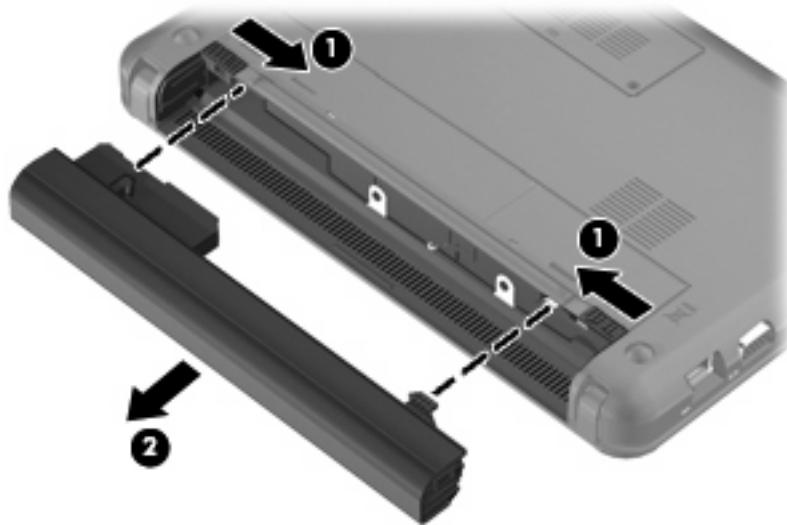

Reverse this procedure to install a battery.

## SIM

 **NOTE:** This section applies only to device models with WWAN capability.

**NOTE:** If there is a SIM inserted in the SIM slot, it must be removed before disassembling the computer. Be sure that the SIM is reinserted in the SIM slot after reassembling the computer.

Before removing the SIM, follow these steps:

1. Shut down the computer. If you are unsure whether the computer is off or in Hibernation, turn the computer on, and then shut it down through the operating system.
2. Disconnect all external devices connected to the computer.
3. Disconnect the power from the computer by first unplugging the power cord from the AC outlet and then unplugging the AC adapter from the computer.
4. Remove the battery (see [Battery on page 44](#)).

Remove the SIM:

1. Press in on the SIM **(1)**. (The module is partially ejected from the SIM slot.)
2. Remove the SIM **(2)** from the SIM slot.

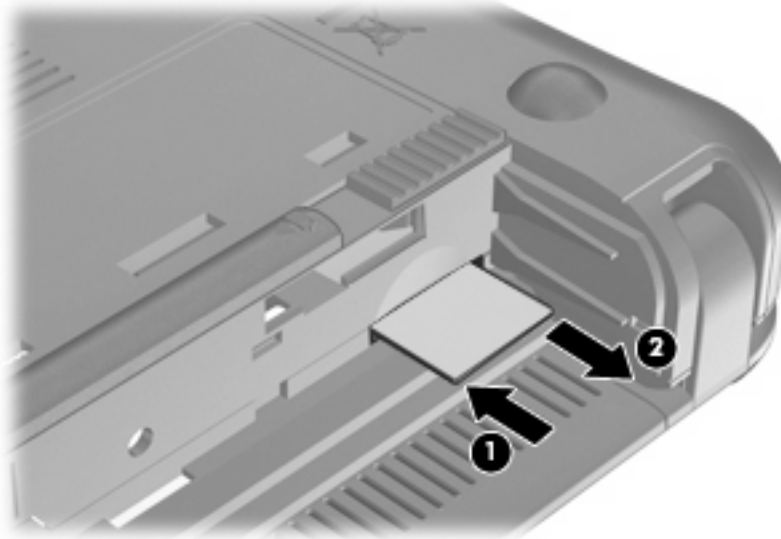

Reverse this procedure to insert the SIM.

## Memory module

Description	Spare part number
<b>Memory module</b> (PC2-5300, 533-MHz, DDR2)	
512-MB (for use in HP Mini 110 and Compaq Mini 110 only)	537663-001
1024-MB	537664-001
2048-MB	537665-001

Before removing the memory module, follow these steps:

1. Shut down the device. If you are unsure whether the device is off or in Hibernation, turn the device on, and then shut it down through the operating system.
2. Disconnect all external devices connected to the device.
3. Disconnect the power from the device by first unplugging the power cord from the AC outlet and then unplugging the AC adapter from the device.
4. Remove the battery (see [Battery on page 44](#)).
5. If your device has WWAN capability, remove the SIM (see [SIM on page 45](#)).

Remove the memory module:

1. Loosen the 2 Phillips 2.0×3.0 captive screws **(1)** that secure the memory module compartment cover to the computer.
2. Swing the cover up and away from the inside of the computer **(2)**, and then remove the cover **(3)**.

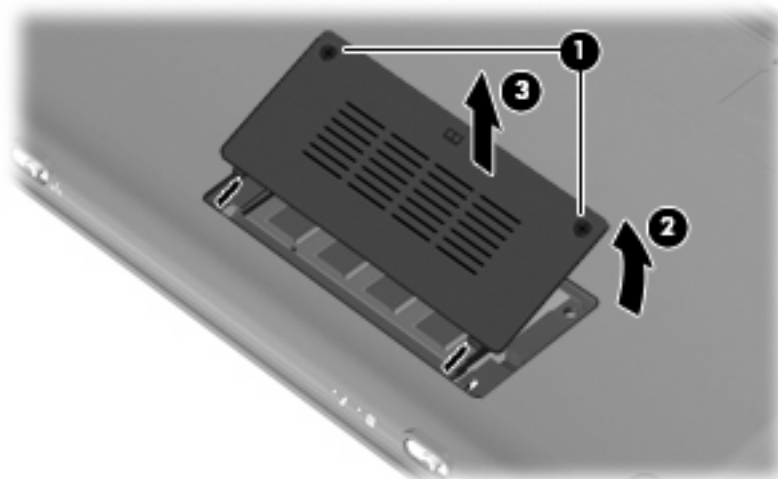

3. Spread the retaining tabs **(1)** on each side of the memory module slot to release the memory module. (The edge of the module opposite the slot rises away from the device.)



4. Remove the memory module (2) by pulling the module away from the slot at an angle.

 **NOTE:** Memory modules are designed with a notch (3) to prevent incorrect insertion into the memory module slot.

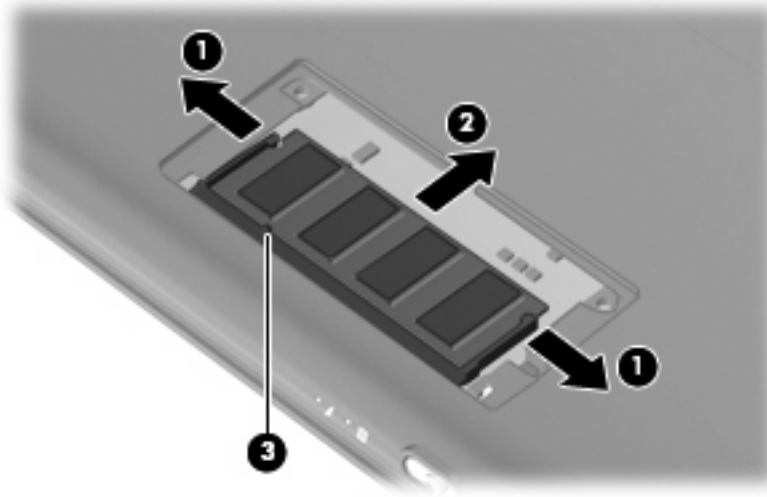

Reverse this procedure to install a memory module.

## Keyboard

Description	Spare part number
<b>For use only on black and blue models with Windows operating system installed</b>	
• For use only in Brazil	535689-201
• For use only in the Czech Republic	535689-221
• For use only in Europe	535689-A41
• For use only in Finland, Norway, and Sweden	535689-DH1
• For use only in France	535689-051
• For use only in French Canada	535689-121
• For use only in Germany	535689-041
• For use only in Greece	535689-151
• For use only in Hungary	535689-211
• For use with international models	535689-B31
• For use only in Israel	535689-BB1
• For use only in Italy	535689-061
• For use only in Japan	535689-291
• For use only in Latin America	535689-161
• For use only in Portugal	535689-131
• For use only in Russia	535689-251
• For use only in Saudi Arabia	535689-171
• For use only in South Korea	535689-AD1
• For use only in Spain	535689-071
• For use only in Switzerland	535689-111
• For use only in Taiwan	535689-AB1
• For use only in Thailand	535689-281
• For use only in Turkey	535689-141
• For use only in the United Kingdom	535689-031
• For use only in the United States	535689-001
<b>For use only on models with Mobile Mi installed</b>	
• For use only in Brazil	535690-201
• For use only in French Canada	535690-121
• For use only in Japan	535690-291
• For use only in Latin America	535690-161
• For use only in South Korea	535690-AD1
• For use only in Taiwan	535690-AB1

<b>Description</b>	<b>Spare part number</b>
• For use only in Thailand	535690-281
• For use only in the United States	535690-001
<b>For use on pink models only</b>	
• For use only in Bosnia, Croatia, Montenegro, Serbia, and Slovenia	537954-BA1
• For use only in Brazil	537954-201
• For use only in the Czech Republic	537954-221
• For use only in Europe	537954-A41
• For use only in Finland, Norway, and Sweden	537954-DH1
• For use only in France	537954-051
• For use only in French Canada	537954-121
• For use only in Germany	537954-041
• For use only in Greece	537954-DJ1
• For use only in Hungary	537954-211
• For use with international models	537954-B31
• For use only in Israel	537954-BB1
• For use only in Italy	537954-061
• For use only in Japan	537954-291
• For use only in Latin America	537954-161
• For use only in Portugal	537954-131
• For use only in Russia	537954-251
• For use only in Saudi Arabia	537954-171
• For use only in South Korea	537954-AD1
• For use only in Spain	537954-071
• For use only in Switzerland	537954-BG1
• For use only in Taiwan	537954-AB1
• For use only in Thailand	537954-281
• For use only in Turkey	537954-141
• For use only in the United Kingdom	537954-031
• For use only in the United States	537954-001
<b>For use with white HP models only</b>	
• For use only in Bosnia, Croatia, Montenegro, Serbia, and Slovenia	537953-BA1
• For use only in Brazil	537953-201
• For use only in the Czech Republic	537953-221
• For use only in Europe	537953-A41

Description	Spare part number
• For use only in Finland, Norway, and Sweden	537953-DH1
• For use only in France	537953-051
• For use only in French Canada	537953-121
• For use only in Germany	537953-041
• For use only in Greece	537953-DJ1
• For use only in Hungary	537953-211
• For use with international models	537953-B31
• For use only in Israel	537953-BB1
• For use only in Italy	537953-061
• For use only in Japan	537953-291
• For use only in Latin America	537953-161
• For use only in Portugal	537953-131
• For use only in Russia	537953-251
• For use only in Saudi Arabia	537953-171
• For use only in South Korea	537953-AD1
• For use only in Spain	537953-071
• For use only in Switzerland	537953-BG1
• For use only in Taiwan	537953-AB1
• For use only in Thailand	537953-281
• For use only in Turkey	537953-141
• For use only in the United Kingdom	537953-031
For use with white HP and HP Mini 110 by Studio Tord Boontje models only in the United States	537953-001

Before removing the keyboard, follow these steps:

1. Shut down the device. If you are unsure whether the device is off or in Hibernation, turn the device on, and then shut it down through the operating system.
2. Disconnect all external devices connected to the device.
3. Disconnect the power from the device by first unplugging the power cord from the AC outlet and then unplugging the AC adapter from the device.
4. Remove the battery (see [Battery on page 44](#)).
5. If your device has WWAN capability, remove the SIM (see [SIM on page 45](#)).

Remove the keyboard:

1. Remove the 3 Phillips SP2.0×3.0 screws that secure the keyboard to the device.



2. Turn the device right-side up, and then open the display as far as possible.
3. Turn the device upside down, and locate the keyboard release access on the bottom of the computer, inside the battery bay.
4. Insert a flexible tool into the opening, and then press inward to release the keyboard.

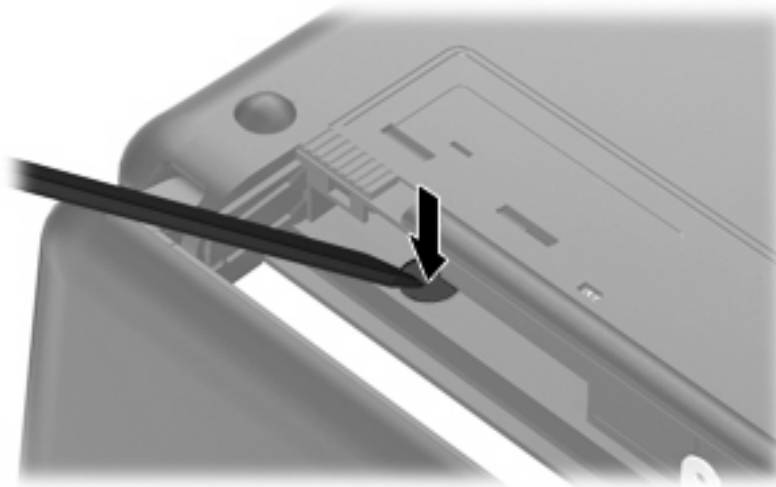

5. Turn the device right-side up, and then lift up on the top and left edges (**1**) of the keyboard until the keyboard releases completely.

6. Slide the keyboard back until its top edge rests on the display assembly **(2)**.



7. Release the zero insertion force (ZIF) connector **(1)** to which the keyboard cable is attached.
8. Disconnect the cable **(2)**, and then remove the keyboard.



9. Remove the keyboard.

Reverse this procedure to install the keyboard.

## RTC battery

Description	Spare part number
RTC battery	537616-001

Before removing the real-time clock (RTC) battery, follow these steps:

1. Shut down the device. If you are unsure whether the device is off or in Hibernation, turn the device on, and then shut it down through the operating system.
2. Disconnect all external devices connected to the device.
3. Disconnect the power from the device by first unplugging the power cord from the AC outlet and then unplugging the AC adapter from the device.
4. Remove the battery (see [Battery on page 44](#)).
5. If your device has WWAN capability, remove the SIM (see [SIM on page 45](#)).
6. Remove the Keyboard (see [Keyboard on page 48](#)).

Remove the RTC battery:

1. Disconnect the RTC battery cable (1) from the system board.
2. Detach the RTC battery (2) from the system board.

 **NOTE:** The RTC battery is attached to the system board with double-sided tape.

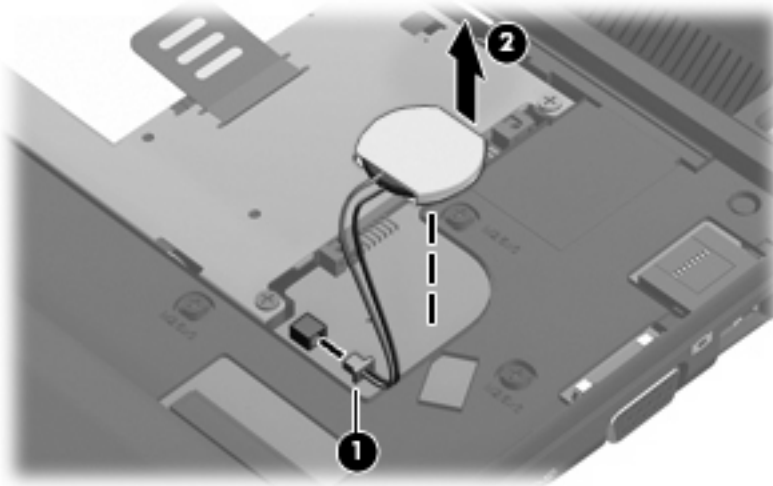

Reverse this procedure to install the RTC battery.

## Mass storage devices

 **NOTE:** Each hard drive spare part kit and solid-state drive spare part kit includes a cable and bracket.

Description	Spare part number
<b>Hard drive</b> (select models only)	
320-GB, 5400-RPM	591398-001
250-GB, 5400-RPM	537635-001
160-GB, 7200-RPM	590669-001
160-GB, 5400-RPM	537634-001
Hard Drive Hardware Kit	537641-001
<b>Solid-state drive</b>	
64-GB	537640-001
32-GB	537639-001
16-GB	537638-001
8-GB	537637-001
Solid-state Drive Hardware Kit	537642-001

Before removing the hard drive or solid-state drive, follow these steps:

1. Shut down the device. If you are unsure whether the device is off or in Hibernation, turn the device on, and then shut it down through the operating system.
2. Disconnect all external devices connected to the device.
3. Disconnect the power from the device by first unplugging the power cord from the AC outlet and then unplugging the AC adapter from the device.
4. Remove the battery (see [Battery on page 44](#)).
5. If your device has WWAN capability, remove the SIM (see [SIM on page 45](#)).
6. Remove the keyboard (see [Keyboard on page 48](#)).

To remove the mass storage assembly:

1. Loosen the Phillips SP2.5×10.0 captive screw **(1)**, and remove the two Phillips PM2.0×5.0 screws **(2)** that secure the assembly to the device.



2. Use the Mylar tab to slide the assembly to the left **(3)** to disconnect it, and remove the assembly **(4)**.

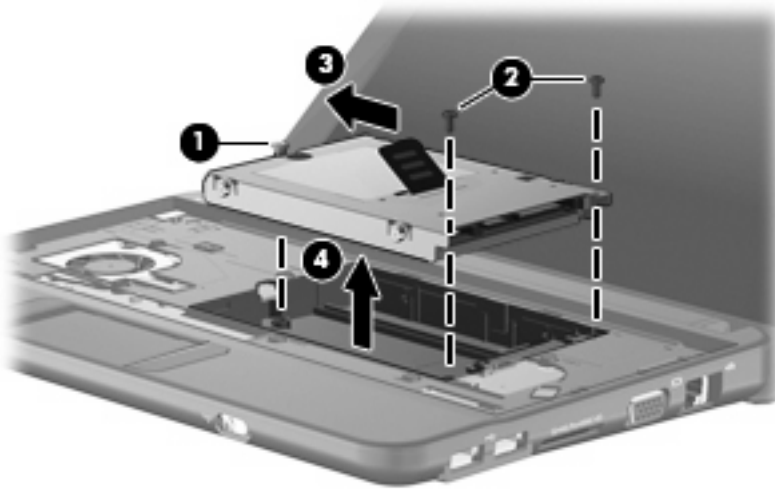

Continue with one of the following sections for hard drive or solid-state drive replacement.

### Hard drive

1. Remove the 4 Phillips SP3.0×4.0 screws **(1)** that secure the hard drive bracket to the hard drive.
2. Using the Mylar tab, lift the bracket **(2)** away from the hard drive.

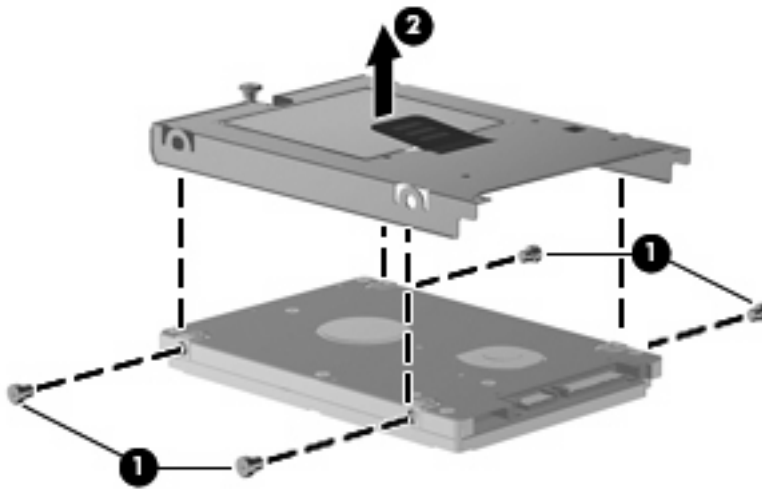

Reverse this procedure to install a hard drive.

### Solid-state drive

To remove the solid-state drive:

1. Remove the 4 Phillips SP2.0×3.0 screws **(1)** that secure the solid-state drive bracket to the solid-state drive.

2. Lift the solid-state drive (2) to remove it.

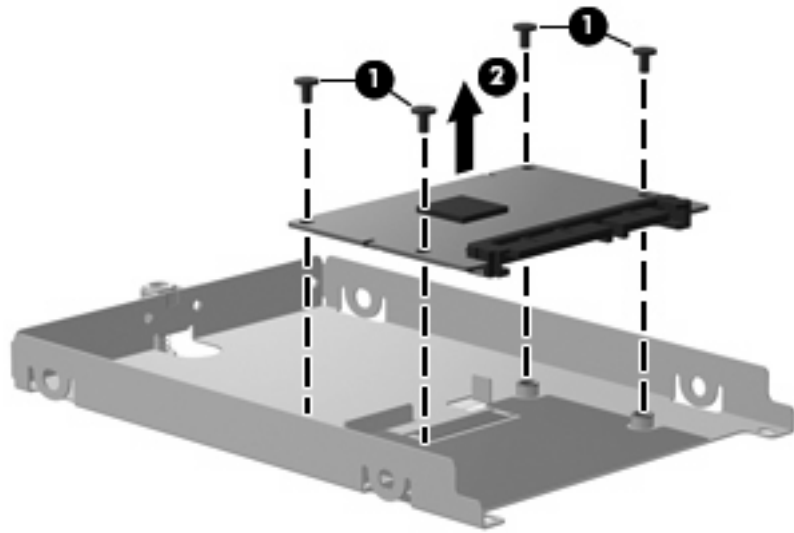

Reverse this procedure to install a solid-state drive.

## Top cover

Description	Spare part number
<b>Top cover</b> (includes TouchPad)	
<ul style="list-style-type: none"><li>For use with black and blue models only</li></ul>	537622-001
<ul style="list-style-type: none"><li>For use with pink HP models only</li></ul>	537625-001
<ul style="list-style-type: none"><li>For use with white HP models only</li></ul>	537624-001
<ul style="list-style-type: none"><li>For use with HP Mini 110 by Studio Tord Boontje models only</li></ul>	579615-001

Before removing the top cover, follow these steps:

1. Shut down the device. If you are unsure whether the device is off or in Hibernation, turn the device on, and then shut it down through the operating system.
2. Disconnect all external devices connected to the device.
3. Disconnect the power from the device by first unplugging the power cord from the AC outlet and then unplugging the AC adapter from the device.
4. Remove the battery (see [Battery on page 44](#)).
5. If your device has WWAN capability, remove the SIM (see [SIM on page 45](#)).
6. Remove the memory module (see [Memory module on page 46](#)).
7. Remove the keyboard (see [Keyboard on page 48](#)).
8. Remove the hard drive or solid-state drive assembly (see [Mass storage devices on page 54](#)).

Remove the top cover.

1. Turn the device upside down, with the front toward you.
2. Use a thin, flat tool to release the 4 tethered rubber feet.
3. Remove the four Phillips PM2.5×7.0 screws (1), and the Phillips SP2.0×5.0 screw (2) that secure the top cover to the base enclosure.

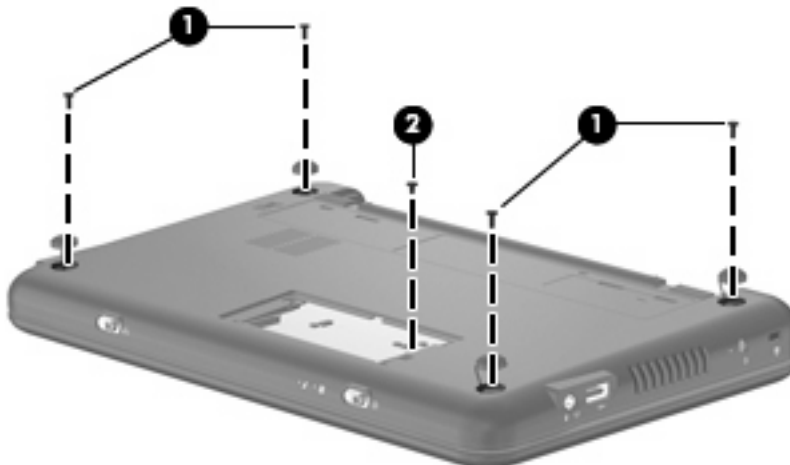

4. Turn the device right-side up, with the front toward you.
5. Open the device as far as possible.
6. Remove the 8 Phillips PM2.5×7.0 screws that secure the top cover to the base enclosure.

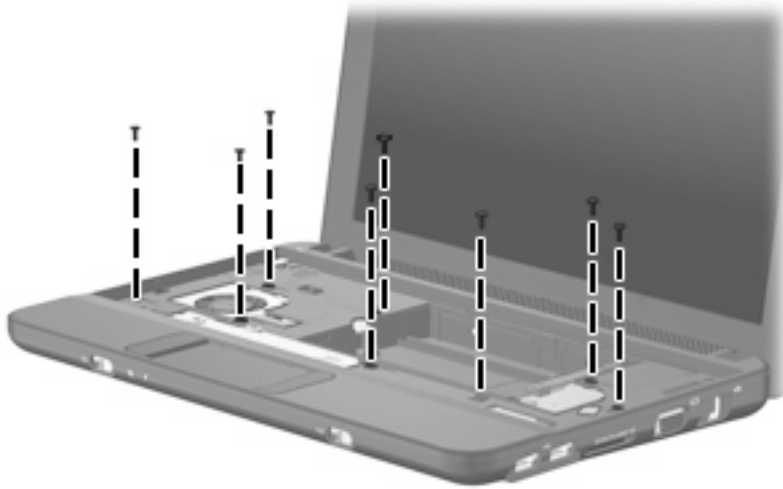

7. Lift the inside edge of the top cover (1) and swing it up. Then slide the top cover back slightly to rest against the display assembly (2) at an angle.



8. Release the ZIF connector (1) to which the TouchPad button board cable is connected.

9. Disconnect the TouchPad button board cable (2) from the system board, and then remove the top cover.

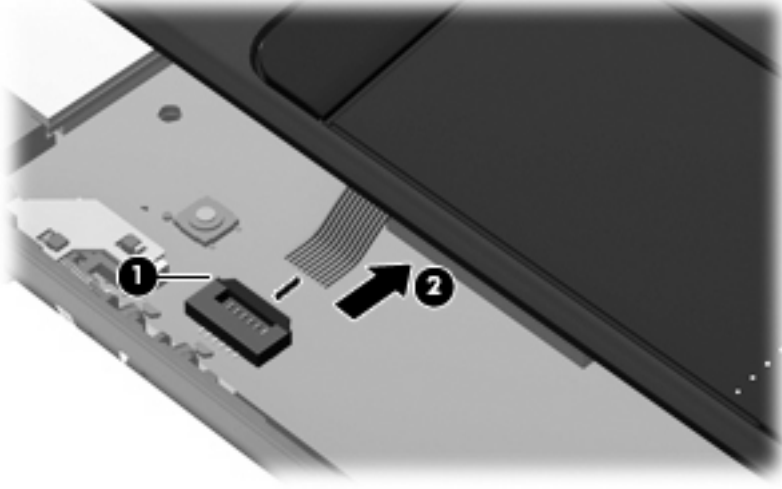

Reverse this procedure to install the top cover.

## WLAN module

Description	Spare part number
<b>WLAN/Bluetooth combination module</b>	575920-001
<b>Broadcom 4312 802.11/b/g/n WLAN module</b>	
For use in Canada, the Cayman Islands, Guam, Puerto Rico, the U.S. Virgin Islands, and the United States	518436-001
For use in Afghanistan, Albania, Algeria, Andorra, Angola, Antigua and Barbuda, Argentina, Armenia, Aruba, Australia, Austria, Azerbaijan, the Bahamas, Bahrain, Bangladesh, Barbados, Belarus, Belgium, Belize, Benin, Bermuda, Bhutan, Bolivia, Bosnia and Herzegovina, Botswana, Brazil, the British Virgin Islands, Brunei, Bulgaria, Burkina Faso, Burundi, Cameroon, Cape Verde, the Central African Republic, Chad, Chile, Colombia, Comoros, the Congo, Costa Rica, Croatia, Cyprus, the Czech Republic, Denmark, Djibouti, Dominica, the Dominican Republic, East Timor, Ecuador, Egypt, El Salvador, Equatorial Guinea, Eritrea, Estonia, Ethiopia, Fiji, Finland, France, French Guiana, Gabon, Gambia, Georgia, Germany, Ghana, Gibraltar, Greece, Grenada, Guadeloupe, Guatemala, Guinea, Guinea-Bissau, Guyana, Haiti, Honduras, Hong Kong, Hungary, Iceland, India, Ireland, Israel, Italy, the Ivory Coast, Jamaica, Jordan, Kazakhstan, Kenya, Kiribati, Kyrgyzstan, Laos, Latvia, Lebanon, Lesotho, Liberia, Liechtenstein, Lithuania, Luxembourg, Macedonia, Madagascar, Malawi, Malaysia, the Maldives, Mali, Malta, the Marshall Islands, Martinique, Mauritania, Mauritius, Mexico, Micronesia, Monaco, Mongolia, Montenegro, Morocco, Mozambique, Namibia, Nauru, Nepal, the Nether Antilles, the Netherlands, New Zealand, Nicaragua, Niger, Nigeria, Norway, Oman, Pakistan, Palau, Panama, Papua New Guinea, Paraguay, the People's Republic of China, Peru, the Philippines, Poland, Portugal, the Republic of Moldova, Romania, Russia, Rwanda, Samoa, San Marino, Sao Tome and Principe, Saudi Arabia, Senegal, Serbia, the Seychelles, Sierra Leone, Singapore, Slovakia, Slovenia, the Solomon Islands, Somalia, South Africa, South Korea, Spain, Sri Lanka, St. Kitts and Nevis, St. Lucia, St. Vincent and the Grenadines, Suriname, Swaziland, Sweden, Switzerland, Taiwan, Tajikistan, Tanzania, Togo, Tonga, Trinidad and Tobago, Tunisia, Turkey, Turkmenistan, Tuvalu, Uganda, Ukraine, the United Arab Emirates, the United Kingdom, Uruguay, Uzbekistan, Vanuatu, Venezuela, Vietnam, Yemen, Zaire, Zambia, and Zimbabwe	518436-002
<b>Broadcom 4312 802.11/b/g WLAN module</b>	
For use in Canada, the Cayman Islands, Guam, Puerto Rico, the U.S. Virgin Islands, and the United States	504593-003
For use in Afghanistan, Albania, Algeria, Andorra, Angola, Antigua and Barbuda, Argentina, Armenia, Aruba, Australia, Austria, Azerbaijan, the Bahamas, Bahrain, Bangladesh, Barbados, Belarus, Belgium, Belize, Benin, Bermuda, Bhutan, Bolivia, Bosnia and Herzegovina, Botswana, Brazil, the British Virgin Islands, Brunei, Bulgaria, Burkina Faso, Burundi, Cameroon, Cape Verde, the Central African Republic, Chad, Chile, Colombia, Comoros, the Congo, Costa Rica, Croatia, Cyprus, the Czech Republic, Denmark, Djibouti, Dominica, the Dominican Republic, East Timor, Ecuador, Egypt, El Salvador, Equatorial Guinea, Eritrea, Estonia, Ethiopia, Fiji, Finland, France, French Guiana, Gabon, Gambia, Georgia, Germany, Ghana, Gibraltar, Greece, Grenada, Guadeloupe, Guatemala, Guinea, Guinea-Bissau, Guyana, Haiti, Honduras, Hong Kong, Hungary, Iceland, India, Ireland, Israel, Italy, the Ivory Coast, Jamaica, Jordan, Kazakhstan, Kenya, Kiribati, Kyrgyzstan, Laos, Latvia, Lebanon, Lesotho, Liberia, Liechtenstein, Lithuania, Luxembourg, Macedonia, Madagascar, Malawi, Malaysia, the Maldives, Mali, Malta, the Marshall Islands, Martinique, Mauritania, Mauritius, Mexico, Micronesia, Monaco, Mongolia, Montenegro, Morocco, Mozambique, Namibia, Nauru, Nepal, the Nether Antilles, the Netherlands, New Zealand, Nicaragua, Niger, Nigeria, Norway, Oman, Pakistan, Palau, Panama, Papua New Guinea, Paraguay, the People's Republic of China, Peru, the Philippines, Poland, Portugal, the Republic of Moldova, Romania, Russia, Rwanda, Samoa, San Marino, Sao Tome and Principe, Saudi Arabia, Senegal, Serbia, the Seychelles, Sierra Leone, Singapore, Slovakia, Slovenia, the Solomon Islands, Somalia, South Africa, South Korea, Spain, Sri Lanka, St. Kitts and Nevis, St. Lucia, St. Vincent and the Grenadines, Suriname, Swaziland, Sweden, Switzerland, Taiwan, Tajikistan, Tanzania, Togo, Tonga, Trinidad and Tobago, Tunisia, Turkey, Turkmenistan, Tuvalu, Uganda, Ukraine, the United Arab Emirates, the United Kingdom, Uruguay, Uzbekistan, Vanuatu, Venezuela, Vietnam, Yemen, Zaire, Zambia, and Zimbabwe	504593-004

△ **CAUTION:** The WWAN module and the WLAN module are not interchangeable.

To prevent an unresponsive system, replace the wireless module only with a wireless module authorized for use in the device by the governmental agency that regulates wireless devices in your country or region. If you replace the module and then receive a warning message, remove the module to restore device functionality, and then contact technical support through Help and Support.

Before removing the WLAN module, follow these steps:

1. Shut down the device. If you are unsure whether the device is off or in Hibernation, turn the device on, and then shut it down through the operating system.
2. Disconnect all external devices connected to the device.
3. Disconnect the power from the device by first unplugging the power cord from the AC outlet and then unplugging the AC adapter from the device.
4. Remove the battery (see [Battery on page 44](#)).
5. If your device has WWAN capability, remove the SIM (see [SIM on page 45](#)).
6. Remove the following components:
  - a. Keyboard (see [Keyboard on page 48](#))
  - b. Hard drive or solid-state drive (see [Mass storage devices on page 54](#))
  - c. Top cover (see [Top cover on page 57](#))

Remove the WLAN module:

1. Remove the 2 Phillips PM2.0×4.0 screws (1) that secure the WLAN module to the system board. (The edge of the module opposite the slot rises away from the device.)
2. Disconnect the wireless antenna cables (2) from the terminals on the WLAN module.
3. Remove the WLAN module (3) by pulling the module away from the slot at an angle.

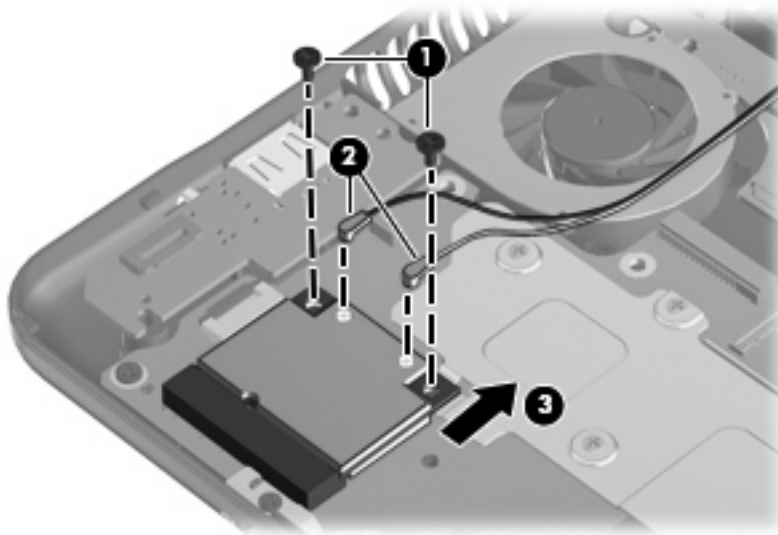

Reverse this procedure to install the WLAN module.

## WWAN module

 **NOTE:** Not available for computers with Mobile Mi installed.

Description	Spare part number
HP un2400 Mobile Broadband Module (select models only)	483377-002
HP un2400 Mobile Broadband Module for use only with Verizon Wireless (select models only)	483377-003
WWAN module for use only in the People's Republic of China	571888-001
HP un2400 Mobile Broadband Module for use only in the People's Republic of China	574246-001
WWAN minicard module	531993-001
WWAN module for use only with Telefonica	592625-161
WWAN module for use only with Am Movil	592624-161
WWAN module for use only with AT&T	591612-001

 **CAUTION:** The WWAN module and the WLAN module are not interchangeable.

To prevent an unresponsive system, replace the wireless module only with a wireless module authorized for use in the device by the governmental agency that regulates wireless devices in your country or region. If you replace the module and then receive a warning message, remove the module to restore device functionality, and then contact technical support.

Before removing the WWAN module, follow these steps:

1. Shut down the device. If you are unsure whether the device is off or in Hibernation, turn the device on, and then shut it down through the operating system.
2. Disconnect all external devices connected to the device.
3. Disconnect the power from the device by first unplugging the power cord from the AC outlet and then unplugging the AC adapter from the device.
4. Remove the battery (see [Battery on page 44](#)).
5. Remove the SIM (see [SIM on page 45](#)).
6. Remove the following components:
  - a. Keyboard (see [Keyboard on page 48](#))
  - b. Hard drive or solid-state drive (see [Mass storage devices on page 54](#))
  - c. Top cover (see [Top cover on page 57](#))

Remove the WWAN module:

1. Remove the 2 Phillips PM2.0×4.0 screws **(1)** that secure the WWAN connector module **(3)** to the system board. (The edge of the module opposite the slot rises away from the device.)
2. Disconnect the wireless antenna cables **(2)** from the terminals on the WWAN module.

 **NOTE:** The red WWAN antenna cable is connected to the WWAN module “Main” terminal. The blue WWAN antenna cable is connected to the WWAN module “Aux” terminal.



3. Remove the WWAN module (3) by pulling the module away from the slot at an angle.

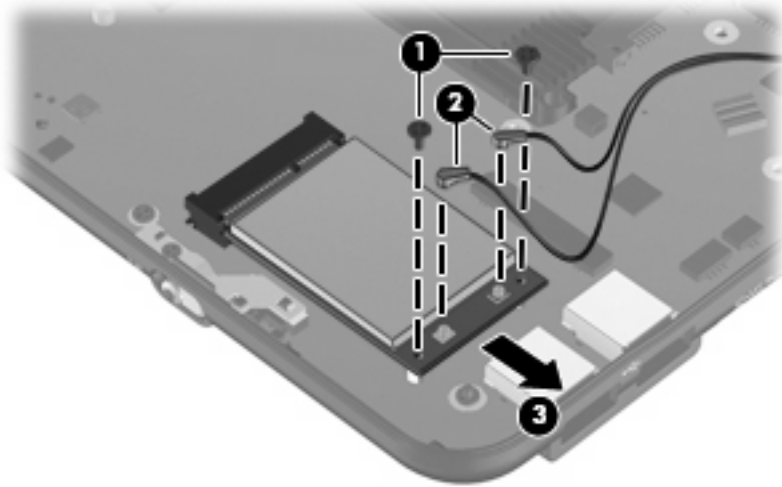

Reverse this procedure to install the WWAN module.

## USB/audio board

Description	Spare part number
<b>USB/audio board</b> (includes cable)	
For use on the following model numbers only: HP: 110-1000 — 110-1099 and Compaq: 110c-1000 — 110-1099	537614-001
For use on the following model numbers only: HP: 110-1100 — 110-1199 and Compaq: 110c-1100 — 110-1199	581325-001

Before removing the USB/audio board, follow these steps:

1. Shut down the computer. If you are unsure whether the computer is off or in Hibernation, turn the computer on, and then shut it down through the operating system.
2. Disconnect all external devices connected to the computer.
3. Disconnect the power from the computer by first unplugging the power cord from the AC outlet and then unplugging the AC Adapter from the computer.
4. Remove the battery (see [Battery on page 44](#)).
5. If your device has WWAN capability, remove the SIM (see [SIM on page 45](#)).
6. Remove the following components:
  - a. Keyboard (see [Keyboard on page 48](#)).
  - b. Hard drive or solid-state drive (see [Mass storage devices on page 54](#)).
  - c. Top cover (see [Top cover on page 57](#)).

Remove the USB board:

1. Release the ZIF connector (1) to which the USB/audio board cable is connected, and disconnect the cable (2).
2. Release the USB/audio board from the clip attached to the base enclosure (3), and remove the USB/audio board (4).

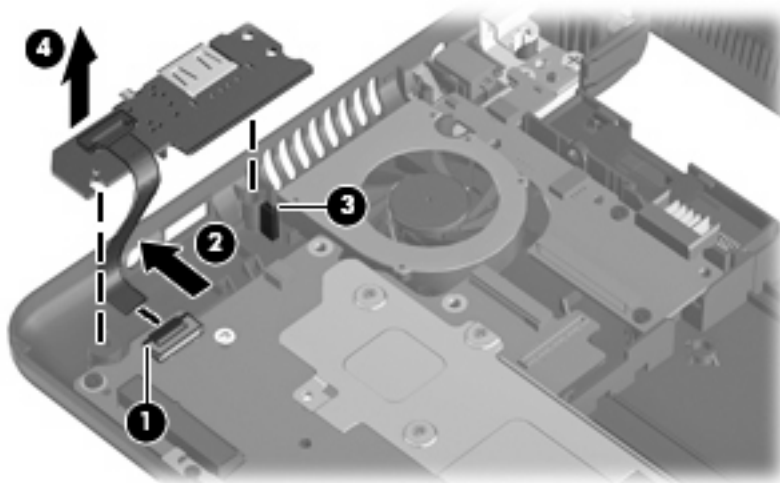

Reverse this procedure to install the USB/audio board.

## Power/battery pass-through board

Description	Spare part number
<b>Power/battery pass-through board</b>	
For use on the following model numbers only: HP: 110-1000 — 110-1099 and Compaq: 110c-1000 — 110-1099	537615-001
For use on the following model numbers only: HP: 110-1100 — 110-1199 and Compaq: 110c-1100 — 110-1199	581326-001

Before removing the power/battery pass-through board, follow these steps:

1. Shut down the device. If you are unsure whether the device is off or in Hibernation, turn the device on, and then shut it down through the operating system.
2. Disconnect all external devices connected to the device.
3. Disconnect the power from the device by first unplugging the power cord from the AC outlet and then unplugging the AC adapter from the device.
4. Remove the battery (see [Battery on page 44](#)).
5. If your device has WWAN capability, remove the SIM (see [SIM on page 45](#)).
6. Remove the following components:
  - a. Keyboard (see [Keyboard on page 48](#))
  - b. Hard drive or solid-state drive (see [Mass storage devices on page 54](#))
  - c. Top cover (see [Top cover on page 57](#))

Remove the power/battery pass-through board:

1. Disconnect the power cable **(1)**.
2. Remove the 2 Phillips BP2.5×5.0 screws **(2)** that secure the power/battery pass-through board to the base enclosure.

3. Remove the power/battery pass-through board (3).

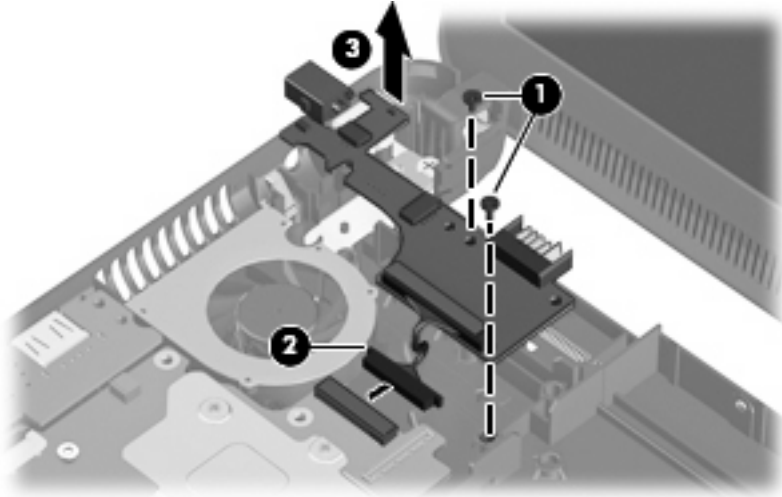

Reverse this procedure to install the power/battery pass-through board.

## Fan

Description	Spare part number
Fan	537613-001

 **NOTE:** To properly ventilate the device, allow at least a 7.6-cm (3-inch) clearance on the left side of the device. The device uses an electric fan for ventilation. The fan is controlled by a temperature sensor and is designed to turn on automatically when high temperature conditions exist. These conditions are affected by high external temperatures, system power consumption, power management/battery conservation configurations, battery fast charging, and software requirements. Exhaust air is displaced through the ventilation grill located on the left side of the device.

Before removing the fan, follow these steps:

1. Shut down the device. If you are unsure whether the device is off or in Hibernation, turn the device on, and then shut it down through the operating system.
2. Disconnect all external devices connected to the device.
3. Disconnect the power from the device by first unplugging the power cord from the AC outlet and then unplugging the AC adapter from the device.
4. Remove the battery (see [Battery on page 44](#)).
5. If your device has WWAN capability, remove the SIM (see [SIM on page 45](#)).
6. Remove the following components:
  - a. Keyboard (see [Keyboard on page 48](#))
  - b. Hard drive or solid-state drive (see [Mass storage devices on page 54](#))
  - c. Top cover (see [Top cover on page 57](#))

Remove the fan:

1. Disconnect the fan cable **(1)**.
2. Remove the 2 Phillips PM2.5×5.0 screws **(2)** that secure the fan to the base enclosure.

3. Remove the fan (3).

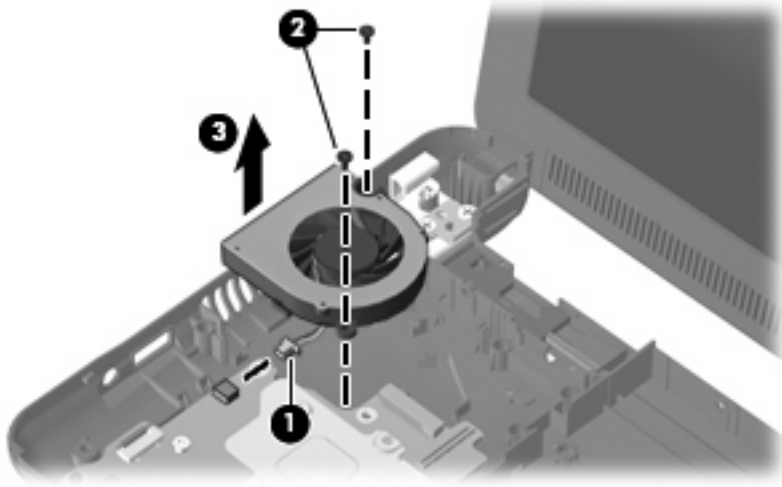

Reverse this procedure to install the fan.

## Heat sink assembly

Description	Spare part number
<b>Heat sink assembly</b> (includes replacement thermal material)	537619-001

Before removing the heat sink assembly, follow these steps:

1. Shut down the device. If you are unsure whether the device is off or in Hibernation, turn the device on, and then shut it down through the operating system.
2. Disconnect all external devices connected to the device.
3. Disconnect the power from the device by first unplugging the power cord from the AC outlet and then unplugging the AC adapter from the device.
4. Remove the battery (see [Battery on page 44](#)).
5. If your device has WWAN capability, remove the SIM (see [SIM on page 45](#)).
6. Remove the following components:
  - a. Keyboard (see [Keyboard on page 48](#))
  - b. Hard drive or solid-state drive (see [Mass storage devices on page 54](#))
  - c. Top cover (see [Top cover on page 57](#))
  - d. WLAN module (see [WLAN module on page 60](#))
  - e. Fan (see [Fan on page 68](#))

Remove the heat sink assembly:

1. Remove the 4 Phillips SP1.5×1.05 screws **(1)** that secure the heat sink assembly to the system board.





**NOTE:** The screws are numbered 1 through 4. Follow this order when removing the screws.

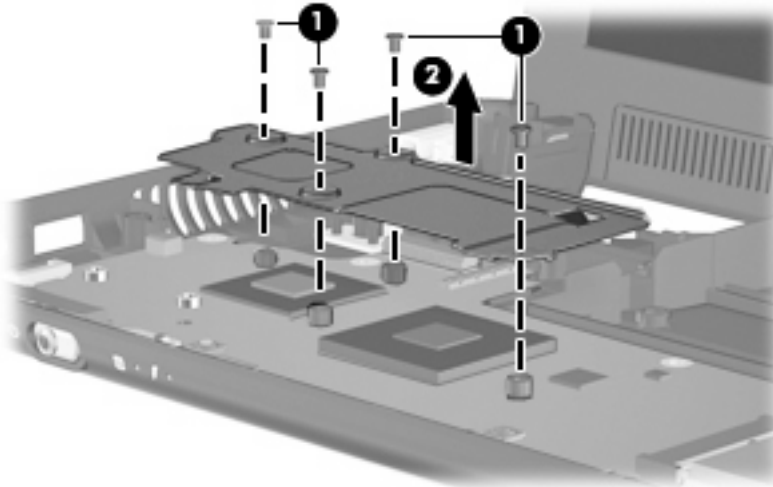

2. Remove the heat sink assembly (2).

 **NOTE:** Due to the adhesive quality of the thermal material located between the heat sink assembly and system board components, it may be necessary to move the heat sink assembly from side to side to detach the assembly.



 **NOTE:** The thermal material must be thoroughly cleaned from the surfaces of the heat sink assembly and the system board each time the heat sink assembly is removed. Thermal paste is used on the processor (1), and thermal tape is used on the Northbridge chip (2). Replacement thermal material is included with all heat sink assembly and system board spare part kits.

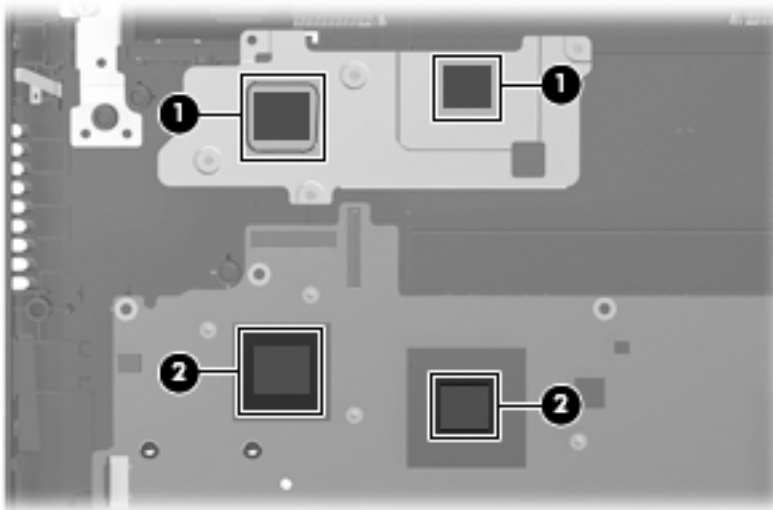

Reverse this procedure to install the heat sink assembly.

## System board

Description	Spare part number
<b>System board</b> (includes processor and replacement thermal material)	
Includes Intel Atom N280 1.66-GHz processor, 512-KB Level 2 cache, 533-MHz front-side bus (FSB)	571370-001
For use on the following model numbers only: HP: 110-1000 — 110-1099 and Compaq: 110c-1000 — 110-1099	
Includes Intel Atom N270 1.6-GHz processor, 512-KB Level 2 cache, 533-MHz front-side bus (FSB)	537662-001
For use on the following model numbers only: HP: 110-1000 — 110-1099 and Compaq: 110c-1000 — 110-1099	
Includes Intel Atom N280 1.66-GHz processor, 512-KB Level 2 cache, 533-MHz front-side bus (FSB)	579569-001
For use on the following model numbers only: HP: 110-1100 — 110-1199 and Compaq: 110c-1100 — 110-1199	
Includes Intel Atom N270 1.6-GHz processor, 512-KB Level 2 cache, 533-MHz front-side bus (FSB)	579568-001
For use on the following model numbers only: HP: 110-1100 — 110-1199 and Compaq: 110c-1100 — 110-1199	

Before removing the system board, follow these steps:

1. Shut down the device. If you are unsure whether the device is off or in Hibernation, turn the device on, and then shut it down through the operating system.
2. Disconnect all external devices connected to the device.
3. Disconnect the power from the device by first unplugging the power cord from the AC outlet and then unplugging the AC adapter from the device.
4. Remove the battery (see [Battery on page 44](#)).
5. If your device has WWAN capability, remove the SIM (see [SIM on page 45](#)).
6. Remove the following components:
  - a. Keyboard (see [Keyboard on page 48](#))
  - b. Hard drive or solid-state drive (see [Mass storage devices on page 54](#))
  - c. Top cover (see [Top cover on page 57](#))

When replacing the system board, be sure that the following components are removed from the defective system board and installed on the replacement system board:

- WLAN module (see [WLAN module on page 60](#))
- WWAN module, if included (see [WWAN module on page 62](#))
- RTC battery (see [RTC battery on page 53](#))
- Heat sink assembly (see [Heat sink assembly on page 70](#))

Remove the system board:

1. Release the tape securing the WWAN antennas (1).
2. Disconnect the following cables from the system board:
  - (2) Display panel cable
  - (3) Microphone cable
  - (4) Speaker cable
  - (5) WLAN cables
  - (6) WWAN cables (select models only)

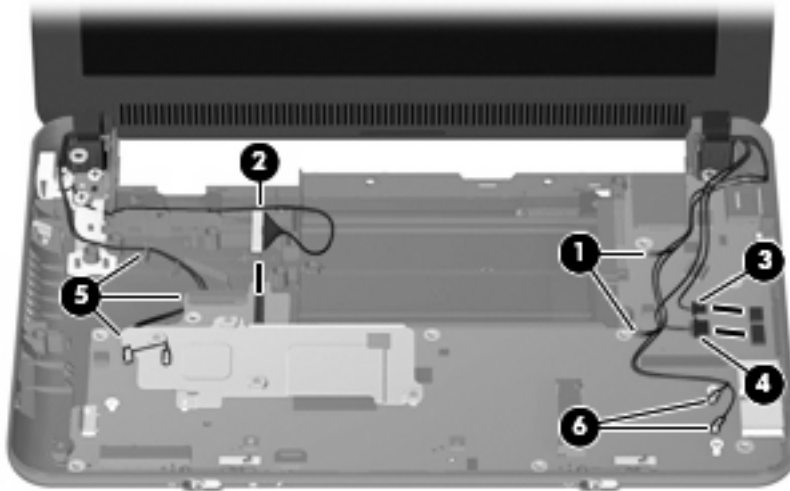

3. Remove the 2 Phillips PM1.5×2.0 screws (1) that secure the actuators for the power switch and wireless on/off switch to the system board.
4. Remove the actuators (2).

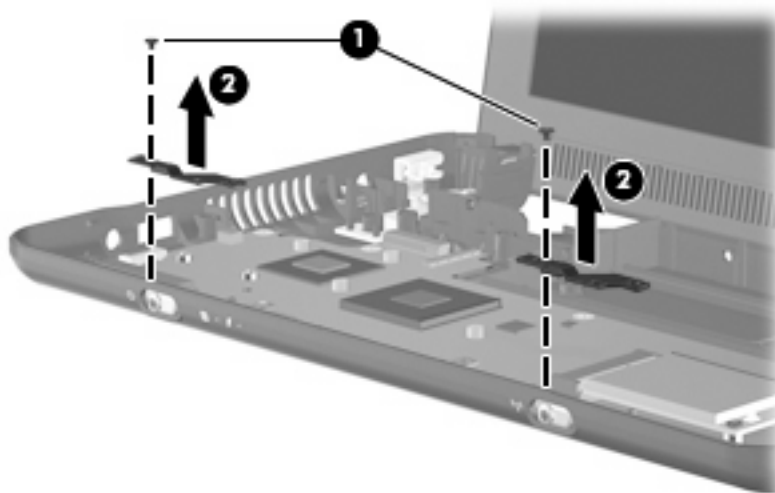

5. Remove the 3 Phillips PM2.5×5.0 screws that secure the system board to the base enclosure.

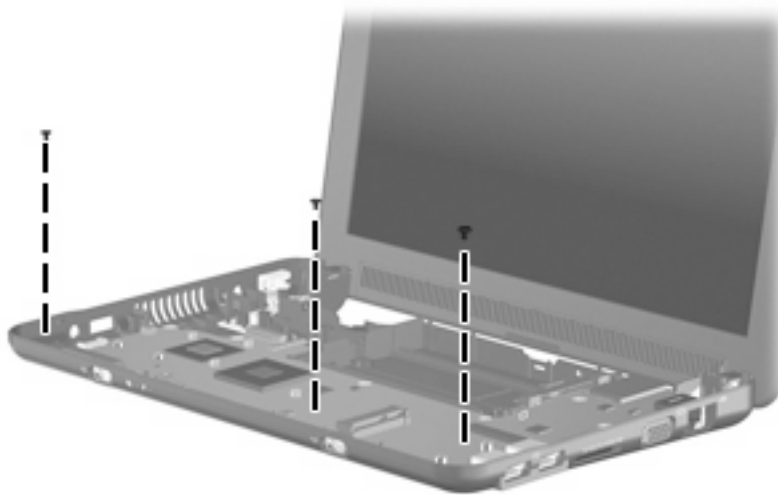

6. Grasp the system board at the midpoint of the left side (1), and lift it up.
7. Pull the system board (2) out to the left at an angle to remove it.

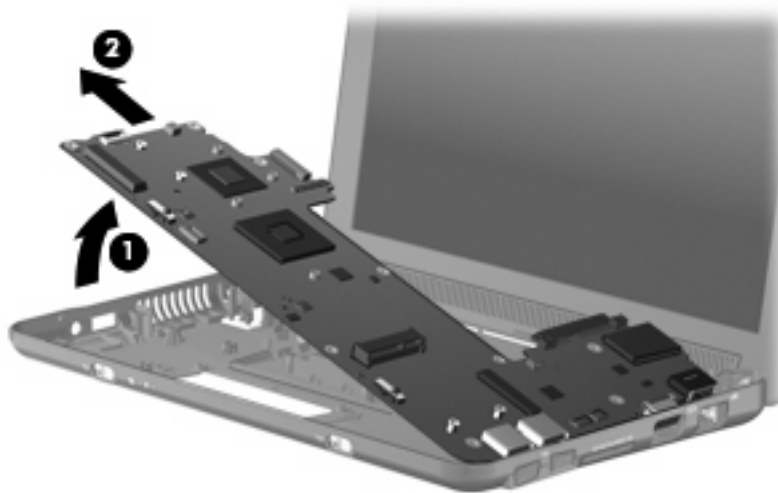

8. Remove the system board.

Reverse the procedure to install the system board.

## Display assembly

 **NOTE:** Each display assembly spare part kit includes 1 webcam, 1 microphone, 1 speaker box, and 2 WLAN antenna transceivers/cables; WWAN on select models only.

Description	Spare part number
<b>For use with black HP models only</b>	
• 10.1-inch, high-definition, AntiGlare display assembly (includes WWAN)	572407-001
• 10.1-inch, high-definition, AntiGlare display assembly	572406-001
• 10.1-inch, standard-definition, AntiGlare display assembly (includes WWAN)	571414-001
• 10.1-inch, standard-definition, AntiGlare display assembly	537646-001
• 10.1-inch, WSVGA, AntiGlare display assembly (includes WWAN)	579604-001
<b>For use with pink HP models only</b>	
• 10.1-inch, high-definition, AntiGlare display assembly (includes WWAN)	572413-001
• 10.1-inch, standard-definition, AntiGlare display assembly (includes WWAN)	571416-001
• 10.1-inch, WSVGA, AntiGlare display assembly (includes WWAN)	579608-001
<b>For use with white HP models only</b>	
• 10.1-inch, high-definition, AntiGlare display assembly (includes WWAN)	572411-001
• 10.1-inch, standard-definition, AntiGlare display assembly (includes WWAN)	571415-001
• 10.1-inch, WSVGA, AntiGlare display assembly (includes WWAN)	579606-001
<b>For use with blue HP models only</b>	
• 10.1-inch, high-definition, AntiGlare display assembly (includes WWAN)	591647-001
• 10.1-inch, WSVGA, AntiGlare display assembly (includes WWAN)	591648-001
<b>For use with HP Mini 110 by Studio Tord Boontje models only</b>	
• 10.1-inch, high-definition, AntiGlare display assembly (includes WWAN)	579612-001
• 10.1-inch, standard-definition, AntiGlare display assembly (includes WWAN)	579610-001
• 10.1-inch, WSVGA, AntiGlare display assembly (includes WWAN)	579614-001
<b>For use with Compaq models only</b>	
• 10.1-inch, high-definition, AntiGlare display assembly	572414-001
• 10.1-inch, standard-definition, AntiGlare display assembly (includes WWAN)	571417-001
• 10.1-inch, standard-definition, AntiGlare display assembly	537643-001
• 10.1-inch, WSVGA, AntiGlare display assembly (includes WWAN)	579626-001
<b>Hinge covers</b>	537617-001
<b>Display bezel</b>	
For use with HP Mini 1101 and HP Mini 110 only	537650-001
For use with HP Mini 110 by Studio Tord Boontje models only	581324-001
For use with Compaq Mini 110 only	537644-001

Description	Spare part number
<b>Display Hinge Kit</b>	537658-001
(Includes left and right display panel hinges)	
<b>Speaker assembly</b> (includes left and right cables)	537621-001
<b>Display panel</b>	
10.1-inch high-definition AntiGlare	572405-001
10.1-inch standard-definition AntiGlare	537656-001
10.1-inch WSVGA AntiGlare	579570-001
<b>Webcam module</b>	537660-001
<b>Display Cable Kit</b> (includes display/webcam cable and WLAN antennas)	
<ul style="list-style-type: none"> <li>• For use with high-definition and standard-definition display panels only</li> </ul>	537657-001
<ul style="list-style-type: none"> <li>• For use with WSVGA display panels only</li> </ul>	579571-001
Microphone assembly	581323-001
WWAN antennas	537655-001
<b>Display enclosure</b> (includes logo)	
For use with black HP models only	537651-001
For use with pink HP models only	537654-001
For use with white HP models only	537653-001
For use with blue HP models only	591649-001
For use with HP Mini 110 by Studio Tord Boontje models only	579576-001
For use with Compaq models only	537645-001
<b>Display Screw Kit</b> (not illustrated)	538510-001

Before removing the display assembly, follow these steps:

1. Shut down the device. If you are unsure whether the device is off or in Hibernation, turn the device on, and then shut it down through the operating system.
2. Disconnect all external devices connected to the device.
3. Disconnect the power from the device by first unplugging the power cord from the AC outlet and then unplugging the AC adapter from the device.
4. Remove the battery (see [Battery on page 44](#)).

5. If your device has WWAN capability, remove the SIM (see [SIM on page 45](#)).
6. Remove the following components:
  - a. Keyboard (see [Keyboard on page 48](#))
  - b. Hard drive or solid-state drive (see [Mass storage devices on page 54](#))
  - c. Top cover (see [Top cover on page 57](#))

Remove the display assembly:

1. Release the tape securing the WWAN antennas (1).
2. Disconnect the following cables from the system board:
  - (2) Display panel cable
  - (3) Microphone cable
  - (4) Speaker cable
  - (5) WLAN cables
  - (6) WWAN cables (select models only)

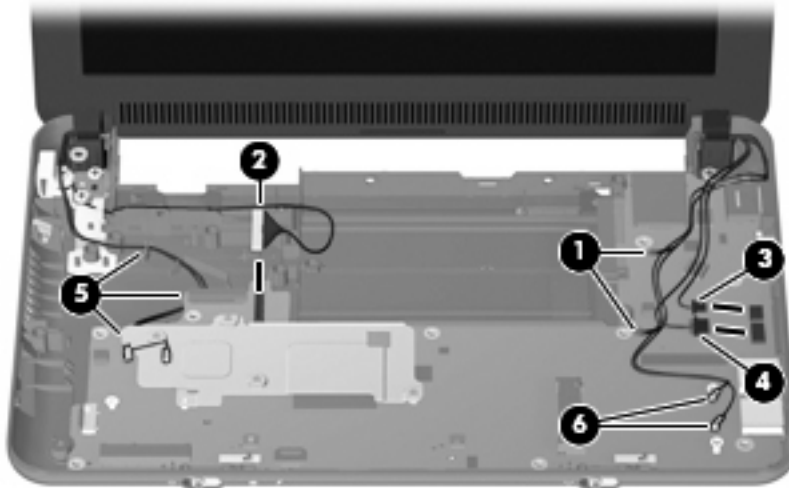

**CAUTION:** Support the display assembly when removing the following screws. Failure to support the display assembly can result in damage to the display assembly and other device components.

3. Remove the 4 Phillips PM2.5×5.0 screws (1) that secure the display assembly to the device.

**NOTE:** One screw on the left hinge (2) also secures the display panel cable ground strap.

4. Remove the display assembly (3).

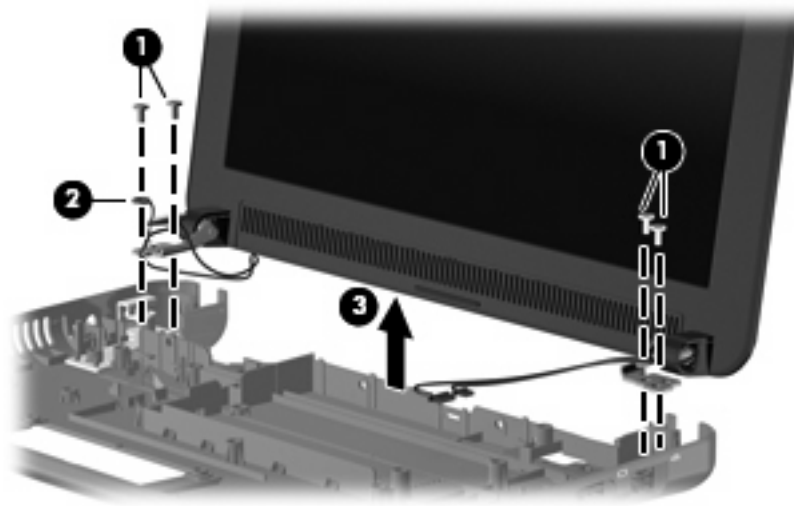

5. If it is necessary to replace the display bezel, perform the following steps:
  - a. Remove the display hinge covers (1).
  - b. Flex the inside edges of the top and bottom (2), and then the left and right sides (3) of the display bezel until the bezel disengages from the display enclosure.
  - c. Remove the display bezel (4).

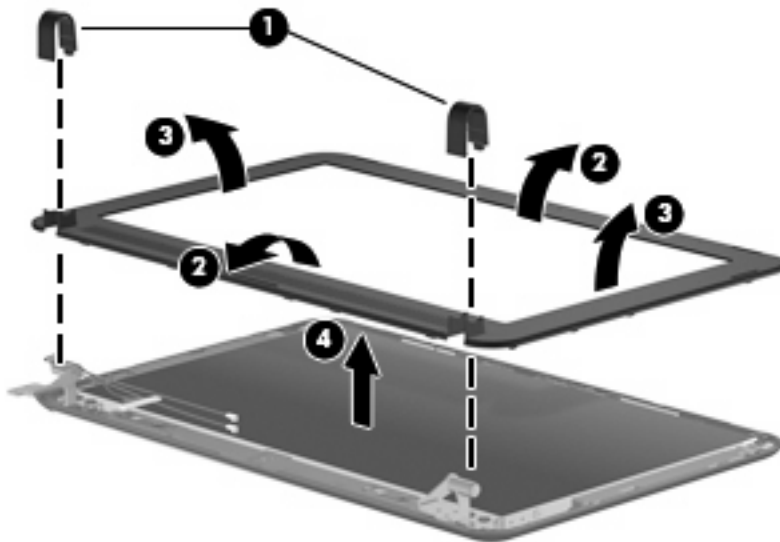



6. If it is necessary to replace the display panel, perform the following steps:
- Remove the 7 Phillips PM2.0×3.0 screws that secure the display panel to the display enclosure.

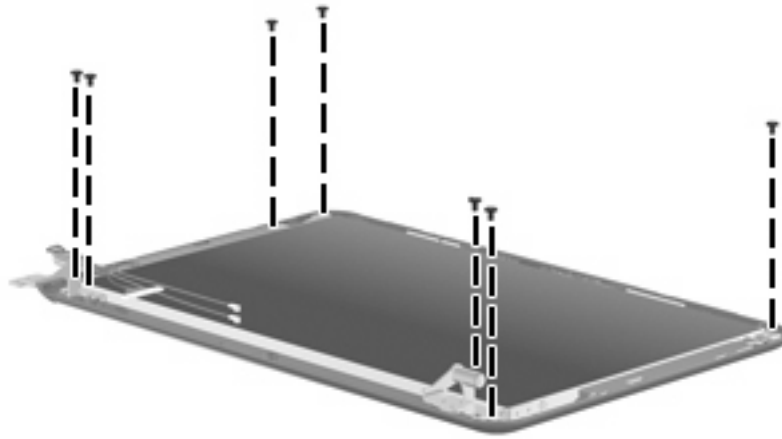

- Lift the display panel up from the display enclosure (1).
- Disconnect the webcam cable (2) from the system board (2).
- Remove the display panel (3) from the display enclosure.

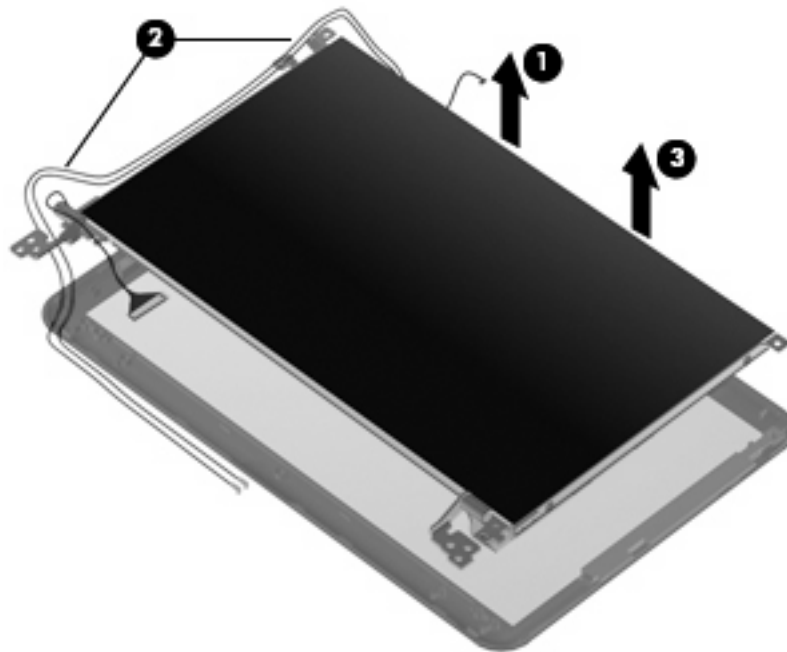

7. If it is necessary to replace the speaker assembly, perform the following steps:
- Remove the three Phillips PM2.0×3.0 screws (1) that secure the speaker assembly to the display enclosure.

- b. Remove the speaker assembly (2).

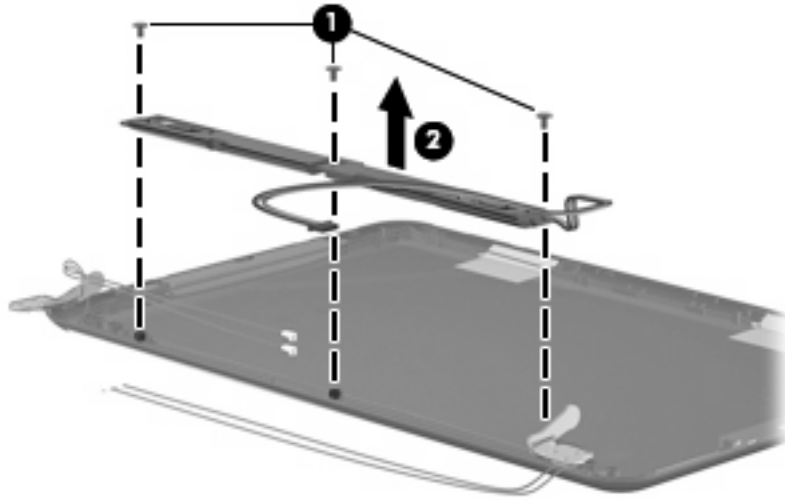

8. If it is necessary to replace the display hinges, perform the following steps:

- a. Remove the 2 Phillips PM2.0×3.0 screws (1) that secure each hinge to the display enclosure.  
b. Remove the hinges (2).

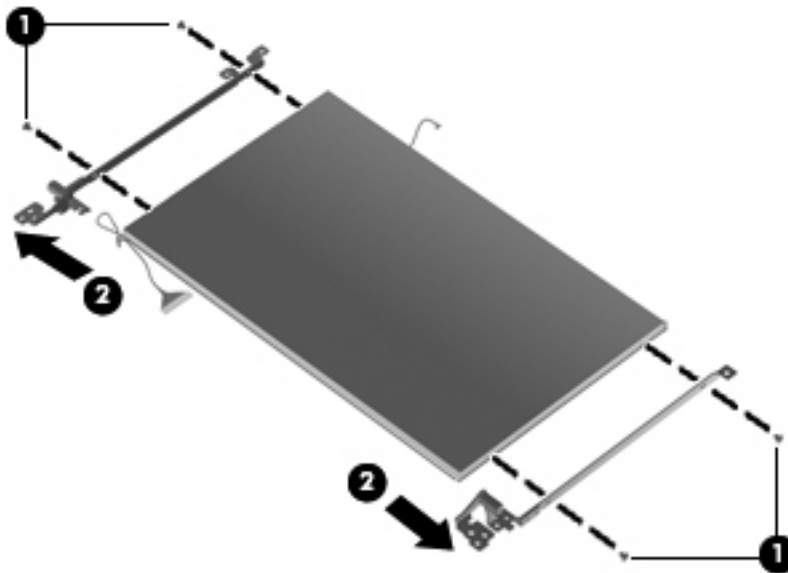

9. If it is necessary to replace the display panel cable, perform the following steps:

- a. Peel back the Mylar protection on the back of the display panel (1).

- b. Disconnect the display panel cable (2).

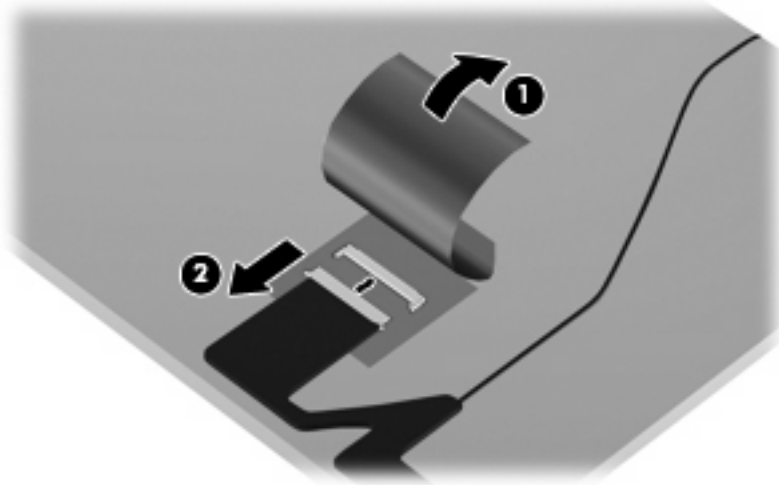

- 10. If it is necessary to replace the webcam module, perform the following steps:

- a. Disconnect the webcam cable (1) from the webcam.
- b. Remove the webcam (2).

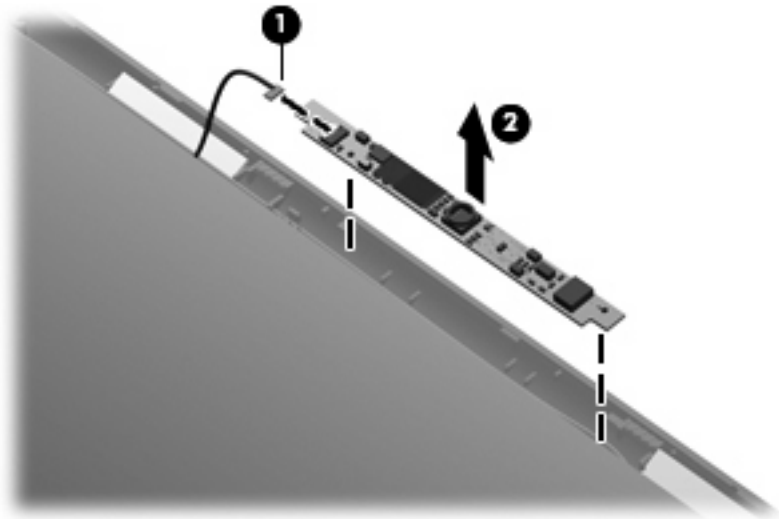

- 11. If it is necessary to replace the microphone receiver, perform the following steps:

- a. Release the microphone receiver from the clip (1) that secures it to the display enclosure.

- b. Pull the receiver through the tabs (2), and remove the microphone receiver (3).

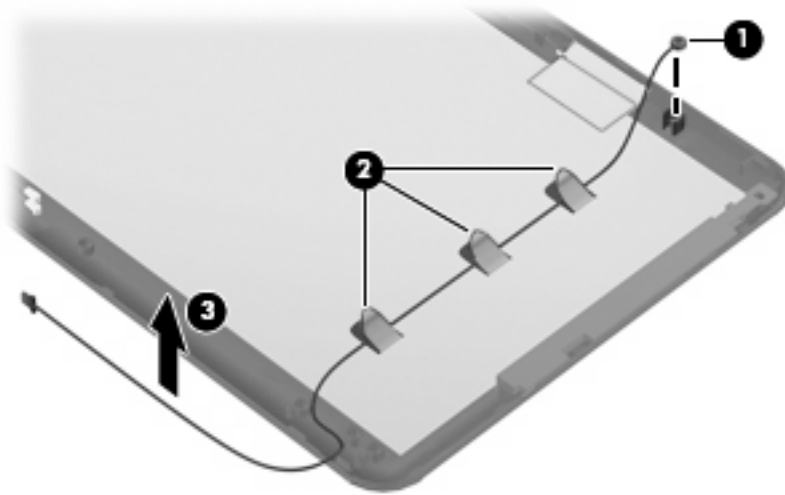

12. If it is necessary to replace the wireless antenna transceivers and cables, detach the cables from the adhesive (1) that secures them to the display enclosure, and then remove the cables (2).

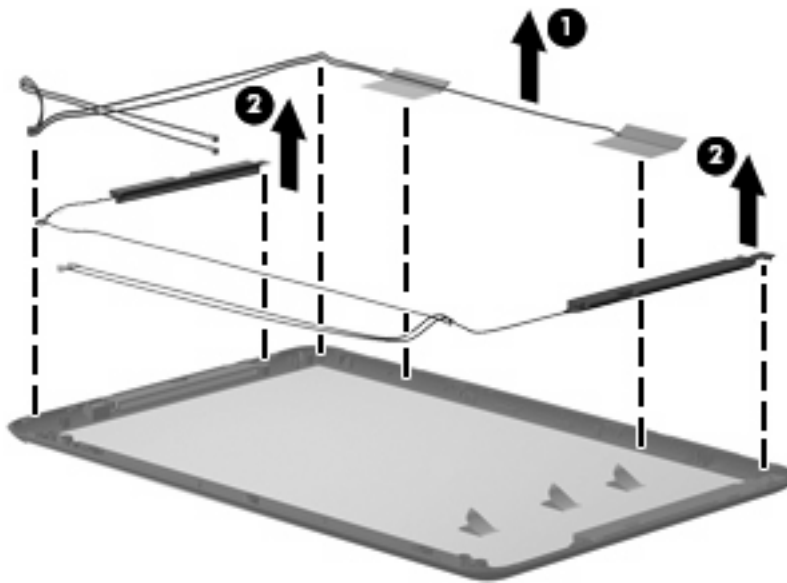

Reverse this procedure to reassemble and install the display assembly.

---

# 5 Setup Utility

## Starting the Setup Utility

The Setup Utility is a ROM-based information and customization utility that can be used even when your operating system is not working.

The utility reports information about the device and provides settings for startup, security, and other preferences.

To start the Setup Utility:

- Open the Setup Utility by turning on or restarting the device, and then pressing **f10** while the “F10 = BIOS Setup Options” message is displayed in the lower-left corner of the screen.

## Using the Setup Utility

### Changing the language of the Setup Utility

The following procedure explains how to change the language of the Setup Utility. If the Setup Utility is not already running, begin at step 1. If the Setup Utility is already running, begin at step 2.

1. Open the Setup Utility by turning on or restarting the device, and then pressing **f10** while the “F10 = BIOS Setup Options” message is displayed in the lower-left corner of the screen.
2. Use the arrow keys to select **System Configuration > Language**, and then press **enter**.
3. Use the arrow keys to select a language, and then press **enter**.
4. When a confirmation prompt with your language selected is displayed, press **enter**.
5. To save your change and exit the Setup Utility, use the arrow keys to select **Exit > Exit Saving Changes**, and then press **enter**.

Your change goes into effect immediately.

### Navigating and selecting in the Setup Utility

Because the Setup Utility is not operating system–based, it does not support the TouchPad. Navigation and selection are by keystroke.

- To choose a menu or a menu item, use the arrow keys.
- To choose an item in a list or to toggle a field, for example an Enable/Disable field, use either the arrow keys or **f5** or **f6**.

- To select an item, press **enter**.
- To close a text box or return to the menu display, press **esc**.
- To display additional navigation and selection information while the Setup Utility is open, press **f1**.

## Displaying system information

The following procedure explains how to display system information in the Setup Utility. If the Setup Utility is not open, begin at step 1. If the Setup Utility is open, begin at step 2.

1. Open the Setup Utility by turning on or restarting the device, and then pressing **f10** while the “F10 = BIOS Setup Options” message is displayed in the lower-left corner of the screen.
2. Select the **Main** menu. System information such as the system time and date, and identification information about the device is displayed.
3. To exit the Setup Utility without changing any settings, use the arrow keys to select **Exit > Exit Discarding Changes**, and then press **enter**.

## Restoring default settings in the Setup Utility

The following procedure explains how to restore the Setup Utility default settings. If the Setup Utility is not already running, begin at step 1. If the Setup Utility is already running, begin at step 2.

1. Open the Setup Utility by turning on or restarting the device, and then pressing **f10** while the “F10 = BIOS Setup Options” message is displayed in the lower-left corner of the screen.
2. Use the arrow keys to select **Exit > Load Setup Defaults**, and then press **enter**.
3. When the Setup Confirmation is displayed, press **enter**.
4. To save your change and exit the Setup Utility, use the arrow keys to select **Exit > Exit Saving Changes**, and then press **enter**.

The Setup Utility default settings go into effect when the device restarts.

 **NOTE:** Your password, security, and language settings are not changed when you restore the factory default settings.

## Exiting the Setup Utility

You can exit the Setup Utility with or without saving changes.

- To exit the Setup Utility and save your changes from the current session:

If the Setup Utility menus are not visible, press **esc** to return to the menu display. Then use the arrow keys to select **Exit > Exit Saving Changes**, and then press **enter**.

- To exit the Setup Utility without saving your changes from the current session:

If the Setup Utility menus are not visible, press **esc** to return to the menu display. Then use the arrow keys to select **Exit > Exit Discarding Changes**, and then press **enter**.

After either choice, the device restarts and loads the operating system.

# Setup Utility menus

The menu tables in this section provide an overview of Setup Utility options.

 **NOTE:** Some of the Setup Utility menu items listed in this chapter may not be supported by your device.

## Main menu

Select	To do this
System information	<ul style="list-style-type: none"><li>• View and change the system time and date.</li><li>• View identification information about the device.</li><li>• View specification information about the processor, memory size, and system BIOS.</li></ul>

## Security menu

Select	To do this
Administrator password	Enter, change, or delete an administrator password.
Power-On Password	Enter, change, or delete a power-on password.

## System Configuration menu

Select	To do this
Language Support	Change the Setup Utility language.
Processor C4 State	Enable/disable the processor C4 sleep state.
Boot Options	<p>Set the following boot options:</p> <ul style="list-style-type: none"><li>• <b>f10</b> and <b>f12</b> Delay (sec.)—Set the delay for the <b>f10</b> and <b>f12</b> functions of the Setup Utility in intervals of 5 seconds each (0, 5, 10, 15, 20).</li><li>• Internal Network Adapter boot—Enable/disable boot from Internal Network Adapter.</li><li>• Boot Order—Set the boot order for:<ul style="list-style-type: none"><li>◦ Internal hard drive (select models only)</li><li>◦ USB Floppy</li><li>◦ USB CD/DVD ROM Drive</li><li>◦ USB flash drive</li><li>◦ USB Hard drive</li><li>◦ USB Card Reader</li><li>◦ Network adapter</li></ul></li></ul> <p><b>NOTE:</b> Only the devices attached to the system will appear in the boot order menu.</p>

## Diagnostics menu

Select	To do this
Hard Disk Self Test (select models only)	Run a comprehensive self-test on the hard drive.
Memory Test	Run a diagnostic test on the system memory.



# 6 Specifications

## Device specifications

	Metric	U.S.
<b>Dimensions</b>		
Depth	16.67 cm	6.56 in
Width	26.17 cm	10.30 in
Height	2.52 cm	0.99 in
<b>Weight</b>		
10.1-in. LCD, equipped with a 3-cell battery, hard drive, 1-GB memory, WLAN module, and 2 wireless antennas	1.11 kg	2.45 lb
10.1-in. LCD, equipped with a 3-cell battery, solid-state drive, 1-GB memory, WLAN module, and 2 wireless antennas	1.09 kg	2.40 lb
<b>Input power</b>		
Operating voltage	19 V dc @ 1.58 A – 30 W	
Operating current	1.58 A	
<b>Temperature</b>		
Operating	5°C to 35°C	41°F to 95°F
Nonoperating	-20°C to 65°C	-4°F to 149°F
<b>Relative humidity (noncondensing)</b>		
Operating	10% to 90%	
Nonoperating	0% to 95%	
<b>Maximum altitude (unpressurized)</b>		
Operating	-15 m to 3,048 m	-50 ft to 10,000 ft
Nonoperating	-15 m to 12,192 m	-50 ft to 40,000 ft
<b>NOTE:</b> Applicable product safety standards specify thermal limits for plastic surfaces. The device operates well within this range of temperatures.		

## 10.1-inch, AntiGlare display specifications

	Metric	U.S.
<b>Dimensions</b>		
Height	23.45 cm	9.23 in
Width	14.30 cm	5.62 in
Diagonal	25.55 cm	10.05 in
<b>Number of colors</b>	262,144	
<b>Contrast ratio</b>	400:1 (typical)	
<b>Brightness</b>	200 nits (typical)	
<b>Pixel resolution</b>		
Pitch	0.2175 × 0.2175 mm	
Format	Standard-definition: 1024 × 576 High-definition: 1366 × 768	
Configuration	RGB vertical stripe	
<b>Backlight</b>	Edge lit	
<b>Character display</b>	80 × 25	
<b>Total power consumption</b>	3.2 W	
<b>Viewing angle</b>	+/-45° horizontal, +15/-35° vertical (typical)	

## 10.1-inch, WSVGA, AntiGlare display specifications

	Metric	U.S.
<b>Dimensions</b>		
Height	12.53 cm	4.93 in
Width	22.27 cm	8.77 in
Diagonal	25.55 cm	10.06 in
<b>Number of colors</b>	262,144	
<b>Contrast ratio</b>	400:1 (typical)	
<b>Brightness</b>	200 nits (typical)	
<b>Pixel resolution</b>		
Pitch	0.2175 × 0.2175 mm	
Format	1024 × 600	
Configuration	RGB vertical stripe	
<b>Backlight</b>	Edge lit	
<b>Character display</b>	80 × 25	
<b>Total power consumption</b>	3.0 W	
<b>Viewing angle</b>	+/-40° horizontal, +20/-40° vertical (typical)	

## Hard drive specifications

	160-GB to 320-GB*
<b>Dimensions</b>	
Height	9.5 mm
Width	70 mm
Weight	101 g
<b>Interface type</b>	PATA
<b>Transfer rate</b>	100 MB/sec
<b>Security</b>	ATA security
<b>Seek times</b> (typical read, including setting)	
Single track	3 ms
Average	13 ms
Maximum	24 ms
<b>Logical blocks</b>	117,210,240
<b>Disc rotational speed</b>	5400 rpm 7200 rpm
<b>Operating temperature</b>	
* 1 GB = 1 billion bytes when referring to hard drive storage capacity. Actual accessible capacity is less. Actual drive specifications may differ slightly.	
<b>NOTE:</b> Certain restrictions and exclusions apply. Contact technical support for details.	

# Solid-state drive specifications

<b>Performance</b>	
Transfer modes supported	UDMA 0-4, Multiword-DMA 0-2, PIO 0-4
Sustained read	39 MB/sec
Sustained write	17 MB/sec
<b>Characteristics</b>	
Interface	Parallel ATA (PATA)
MLC NAND flash capacity	8 GB, 16 GB
<b>Electrical specifications</b>	
DC supply voltage	3.3 V +/- 5%
Standby current	300 µA (typical)
Active current	Read = 130 mA (typical) Write = 120 mA (typical)
<b>Environmental specifications</b>	
Operating temperature	0°C to +70°C (32°F to 158°F)
Storage temperature	-25°C to +85°C (-13°F to 185°F)
Operating altitude	up to 24,384 m (80,000 feet)
Humidity	5% to 90% non-condensing
Shock	1,000 g
Acoustic noise	0 dB
Vibration	15 g (peak to peak)
<b>Physical specifications</b>	
Connector	40-pin ZIF connector
Weight (8-GB model)	5.5 g
Weight (16-GB model)	7.0 g
Dimensions (8-GB model)	54 × 32 × 2.6 mm
Dimensions (16-GB model)	54 × 32 × 3.75 mm
<b>Regulations and compliance</b>	
	RoHS, China RoHS, SGS ROHS, FCC, CE UL – PCB Only

## System DMA specifications

Hardware DMA	System function
DMA0	Not applicable
DMA1*	Not applicable
DMA2*	Not applicable
DMA3	Not applicable
DMA4	Direct memory access controller

# System interrupt specifications

Hardware IRQ	System function
IRQ0	System timer
IRQ1	Standard 101-/102-Key or Microsoft® Natural PS/2 Keyboard
IRQ8	System CMOS/real-time clock
IRQ9 *	Microsoft ACPI-compliant system
IRQ12	Synaptics PS/2 TouchPad
IRQ13	Numeric data processor
IRQ14	Primary IDE channel
IRQ15	Intel® 82801G (ICH7 Family) SMBus Controller—27DA
IRQ16	Broadcom 802.11b/g WLAN no. 2 Intel 82801G (ICH7 Family) PCI Express Root Port—27D0 Intel 82801G (ICH7 Family) USB Universal Host Controller—27CB Microsoft UAA Bus Driver for High Definition Audio Mobile Intel 945 Express Chipset Family
IRQ17	Intel 82801G (ICH7 Family) PCI Express Root Port—27D2
IRQ18	Intel 82801G (ICH7 Family) USB Universal Host Controller—27CA
IRQ19	Intel 82801G (ICH7 Family) USB Universal Host Controller—27C9
IRQ23	Intel 82801G (ICH7 Family) USB Universal Host Controller—27C8 Intel 82801G (ICH7 Family) USB2 Enhanced Host Controller—27CC
* Default configuration	

## System I/O address specifications

I/O address (hex)	System function (shipping configuration)
000 - 00F	DMA controller
000 - CF7	PCI bus
010 - 01F	Motherboard resources
020 - 021	Programmable interrupt controller
022 - 03F	Motherboard resources
040 - 043	System timer
044 - 05F	Motherboard resources
060 - 060	Standard 101-/102-Key or Microsoft® Natural PS/2 Keyboard
061 - 061	System speaker
062 - 062	Microsoft ACPI-Compliant Embedded Controller
063- 063	Motherboard resources
064 - 064	Standard 101-/102-Key or Microsoft Natural PS/2 Keyboard
065 - 065	Motherboard resources
066 - 066	Microsoft ACPI-Compliant Embedded Controller
067 - 06F	Motherboard resources
070 - 071	System CMOS/real-time clock
072 - 07F	Motherboard resources
080 - 080	Motherboard resources
081 - 083	DMA controller
084 - 086	Motherboard resources
087 - 087	DMA controller
088 - 088	Motherboard resources
089 - 08B	DMA controller
08C - 08E	Motherboard resources
08F - 08F	DMA controller
090 - 09F	Motherboard resources
0A0 - 0A1	Programmable interrupt controller
0A2 - 0BF	Motherboard resources
0C0 - 0DF	DMA controller
0E0 - 0EF	Motherboard resources
0F0 - 0FF	Numeric data processor
1F0 - 1F7	Primary IDE channel
274 - 277	ISAPNP Read Data Port



<b>I/O address (hex)</b>	<b>System function (shipping configuration)</b>
279 - 279	ISAPNP Read Data Port
3B0 - 3BB	Mobile Intel® 945 Express Chipset Family
3C0 - 3DF	Mobile Intel 945 Express Chipset Family
3F6 - 3F6	Primary IDE channel
400 - 41F	Intel 82801G (ICH7 Family) SMBus Controller—27DA
480 - 4BF	Motherboard resources
4D0 - 4D1	Motherboard resources
500 - 501	Motherboard resources
800 - 87F	Motherboard resources
A79 - A79	ISAPNP Read Data Port
0D00 - FFFF	PCI bus
D480 - D49F	Intel 82801G (ICH7 Family) USB Universal Host Controller—27C8
D800 - D81F	Intel 82801G (ICH7 Family) USB Universal Host Controller—27CA
D880 - D89F	Intel 82801G (ICH7 Family) USB Universal Host Controller—27C9
DC00 - DC1F	Intel 82801G (ICH7 Family) USB Universal Host Controller—27C8
DC80 - DC87	Mobile Intel 945 Express Chipset Family
E000 - EFFF	Intel 82801G (ICH7 Family) PCI Express Root Port—27D2
FFA0 - FFAF	Intel 82801G (ICH7 Family) Ultra ATA Storage Controllers—27DF

## System memory map specifications

Memory address	System function
00000000 - 0009FFFF	System board
000A0000 - 000BFFFF	Mobile Intel® 945 Express Chipset Family
000A0000 - 000BFFFF	PCI bus
000C0000 - 000CFFFF	System board
000D0000 - 000DFFFF	PCI bus
000E0000 - 000FFFFFF	System board
00100000 - 3F7FFFFFF	System board
3F800000 - DFFFFFFF	PCI bus
D0000000 - DFFFFFFF	Mobile Intel 945 Express Chipset Family
E0000000 - E3FFFFFF	Motherboard resources
E4000000 - FED8FFFF	PCI bus
FE880000 - FE8FFFFF	Mobile Intel 945 Express Chipset Family
FE937C00 - FE937FFF	Intel 82801G (ICH7 Family) USB2 Enhanced Host Controller—27CC
FE938000 - FE93BFFF	Microsoft® UAA Bus Driver for High Definition Audio
FE940000 - FE97FFFF	Mobile Intel 945 Express Chipset Family
FE980000 - FE9FFFFFF	Mobile Intel 945 Express Chipset Family
FEA00000 - FEAFFFFFF	Intel 82801G (ICH7 Family) PCI Express Root Port—27D0
FEAFC000 - FEAFFFFFF	Broadcom 802.11b/g WLAN
FEB00000 - FEBFFFFFF	Intel 82801G (ICH7 Family) PCI Express Root Port—27D2
FEC00000 - FEC00FFF	Motherboard resources
FED13000 - FED19FFF	System board
FED1C000 - FED1FFFF	Motherboard resources
FED20000 - FED3FFFF	Motherboard resources
FED40000 - FED8FFFF	Motherboard resources
FED90000 - FFFFFFFF	System board
FEE00000 - FEE00FFF	Motherboard resources

## 7 Screw listing

This section provides specification and reference information for the screws and screw locks used in the device. All screws listed in this section are available in the Screw Kit, spare part number 537620-001; or in the Display Screw Kit, spare part number 538510-001.

### Phillips PM1.5×1.0 screw

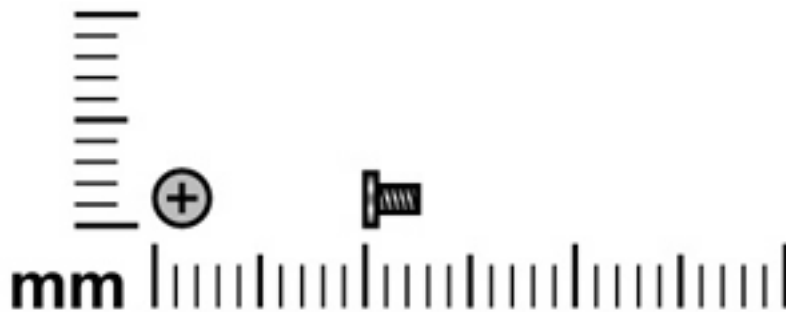

Color	Quantity	Length	Thread	Head diameter
Silver	6	1.0 mm	1.5 mm	1.0 mm

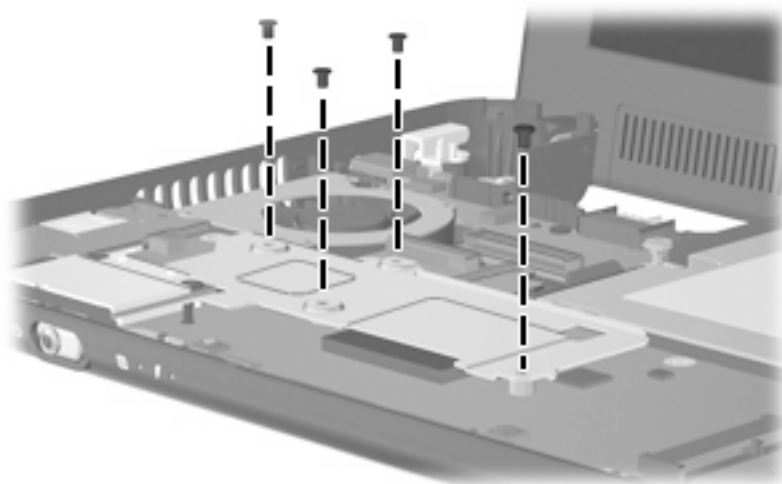

**Where used:** 4 screws that secure the heat sink to the system board

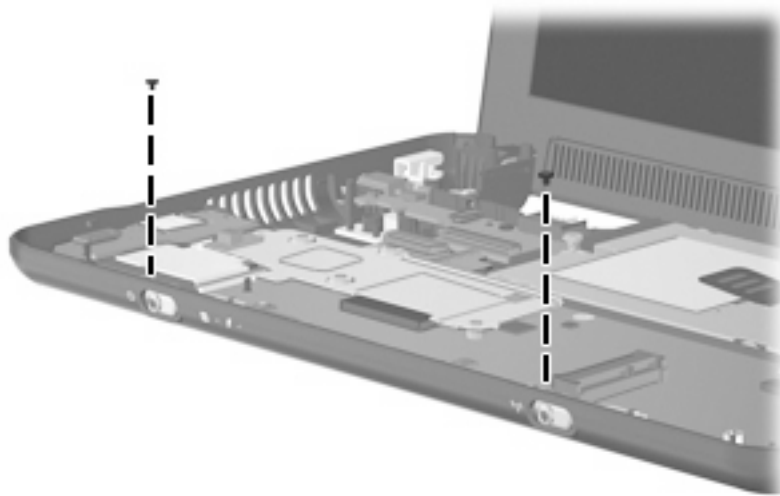

**Where used:** Two screws that secure the power and wireless switch actuators to the base enclosure

# Phillips PM2.0×3.0 screw

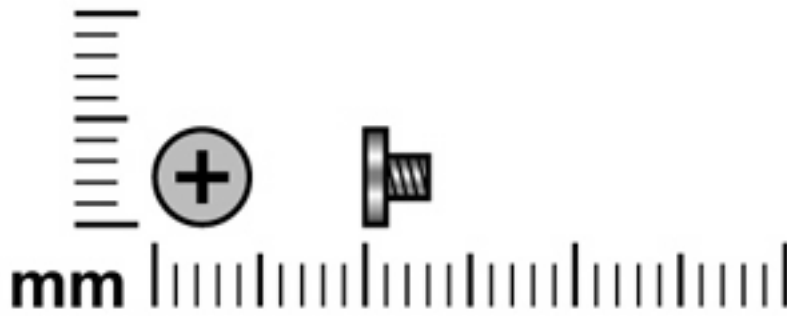

Color	Quantity	Length	Thread	Head diameter
Black	20	3.0 mm	2.0 mm	4.0 mm



**Where used:** 3 screws that secure the keyboard to the device

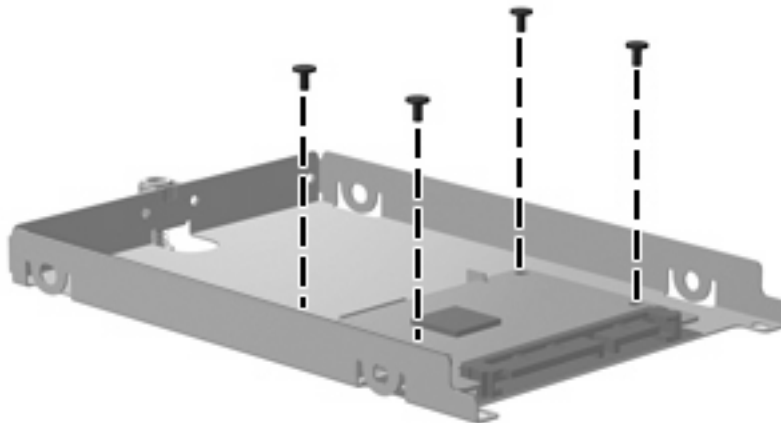

**Where used:** Four screws that secure the solid-state drive to the bracket

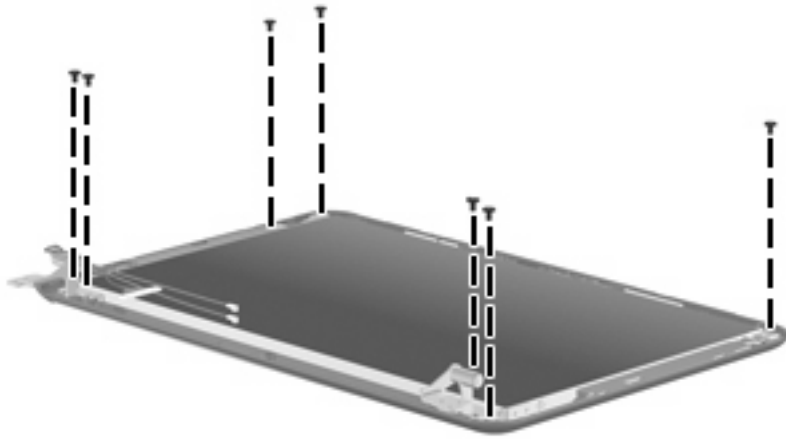

**Where used:** Seven screws that secure the display panel to the display enclosure

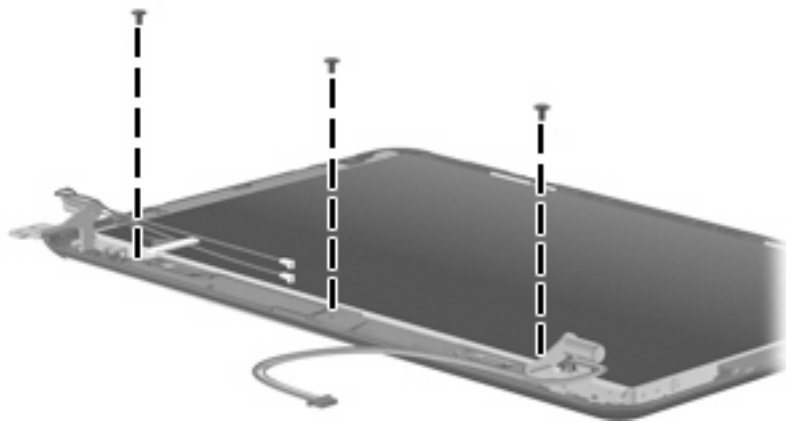

**Where used:** Three screws that secure the speaker assembly to the display enclosure

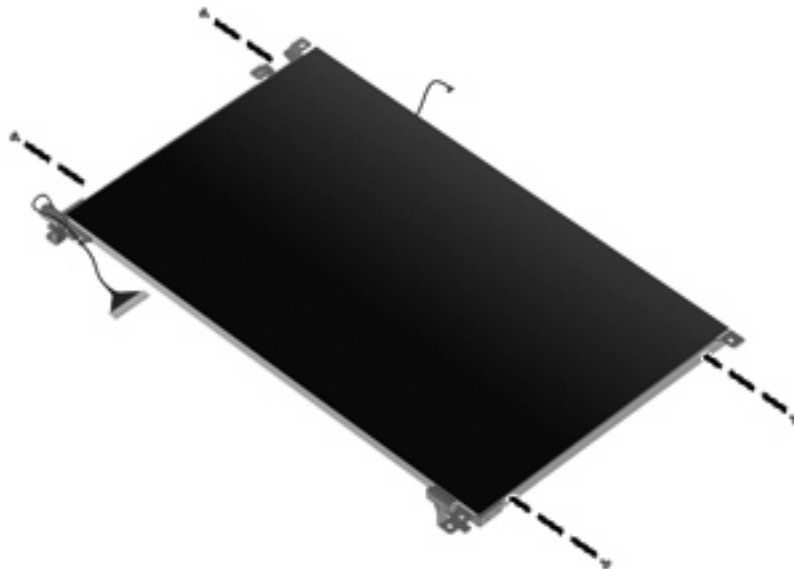

**Where used:** Four screws that secure the hinges to the display panel

## Phillips PM2.0×3.0 captive screw

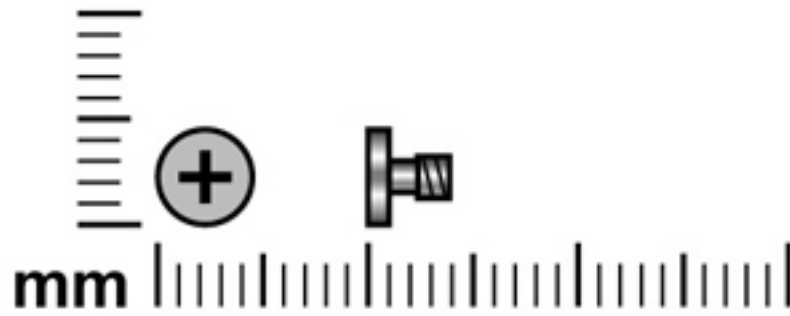

Color	Quantity	Length	Thread	Head diameter
Black	2	3.0 mm	2.0 mm	4.0 mm



## Phillips PM2.0×4.0 screw

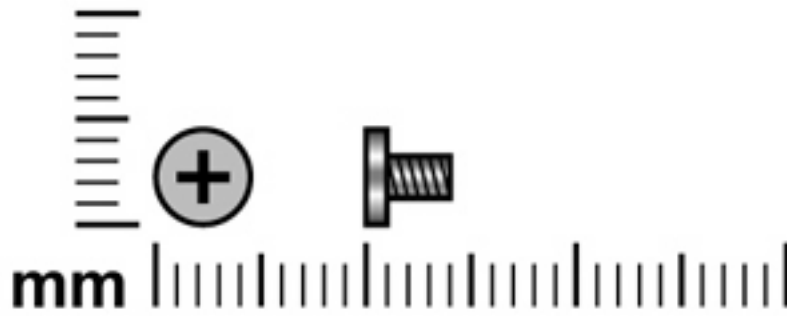

Color	Quantity	Length	Thread	Head diameter
Silver	4	4.0 mm	2.0 mm	4.0 mm

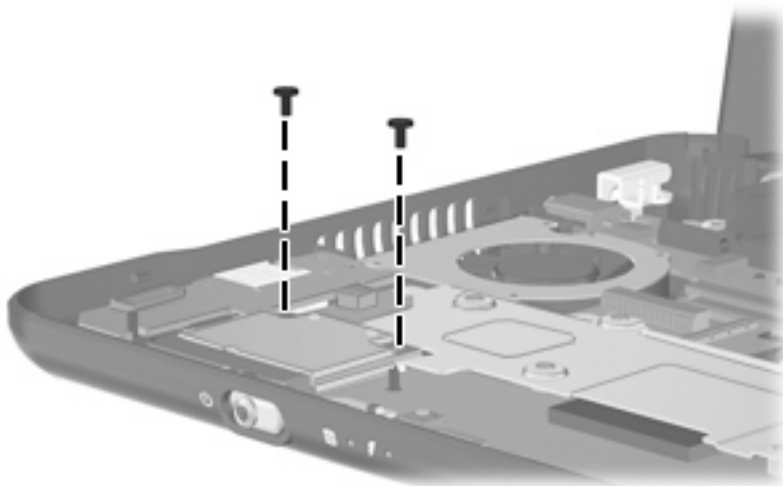

**Where used:** Two screws that secure the WLAN module to the system board

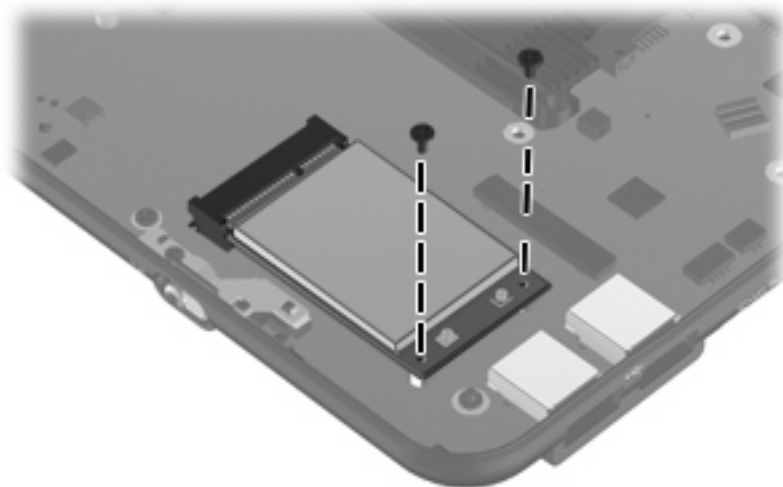

**Where used:** Two screws that secure the WWAN to the system board



## Phillips PM2.0×5.0 screw

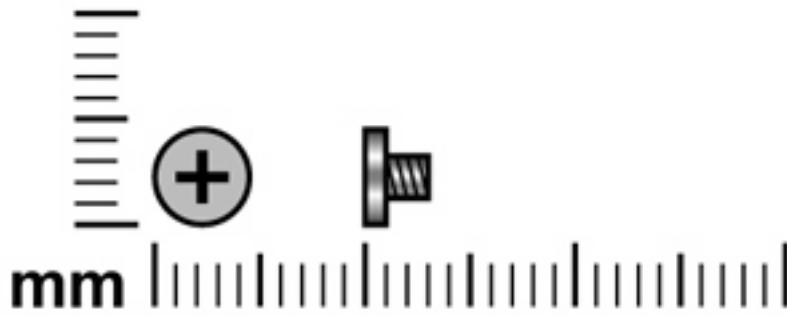

Color	Quantity	Length	Thread	Head diameter
Silver	3	5.0 mm	2.0 mm	4.5 mm

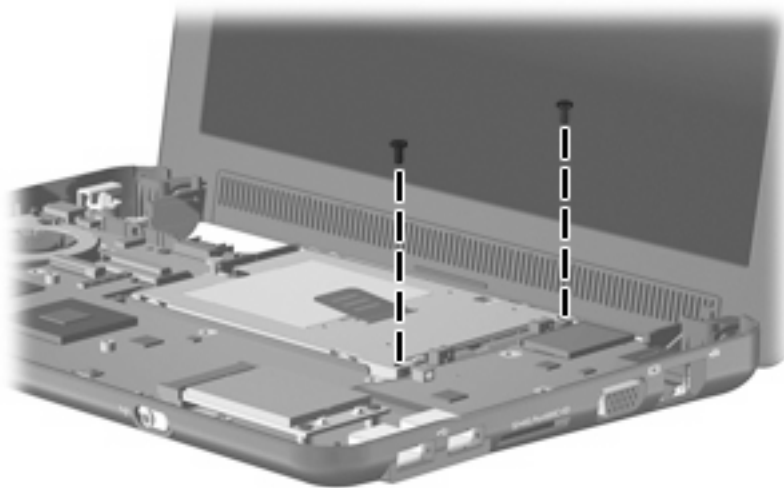

**Where used:** Two screws that secure the hard drive or solid-state drive to the system board



**Where used:** One screw that secures the top cover to the base enclosure

## Phillips PM2.5×5.0 screw

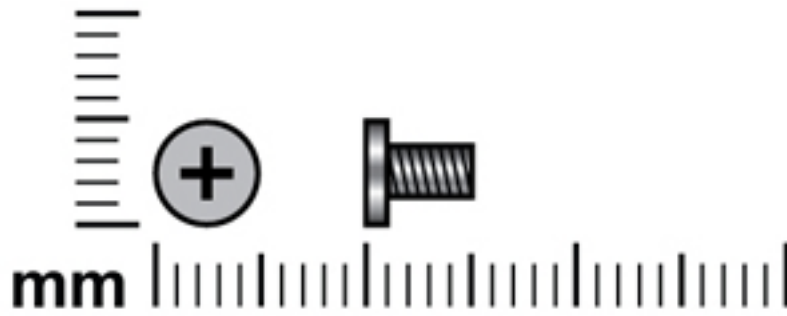

Color	Quantity	Length	Thread	Head diameter
Silver	15	5.0 mm	2.5 mm	4.5 mm

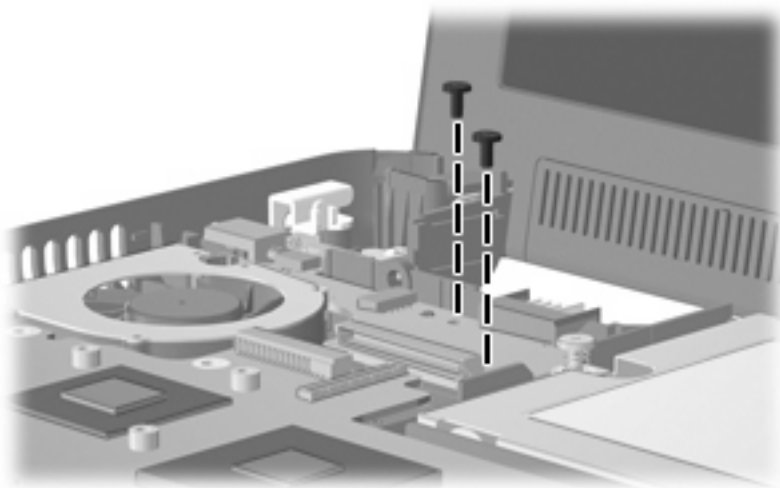

**Where used:** Two screws that secure the power/battery pass-through board to the system board

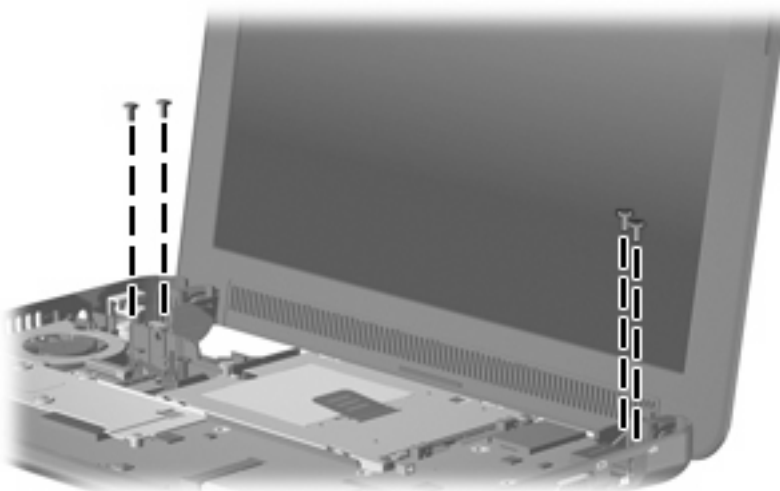

**Where used:** Four screws that secure the display assembly and top cover to the device

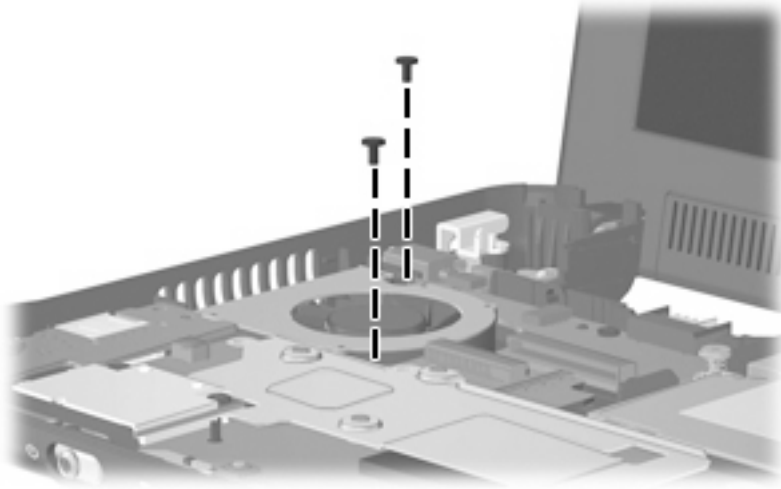

**Where used:** Two screws that secure the fan to the system board

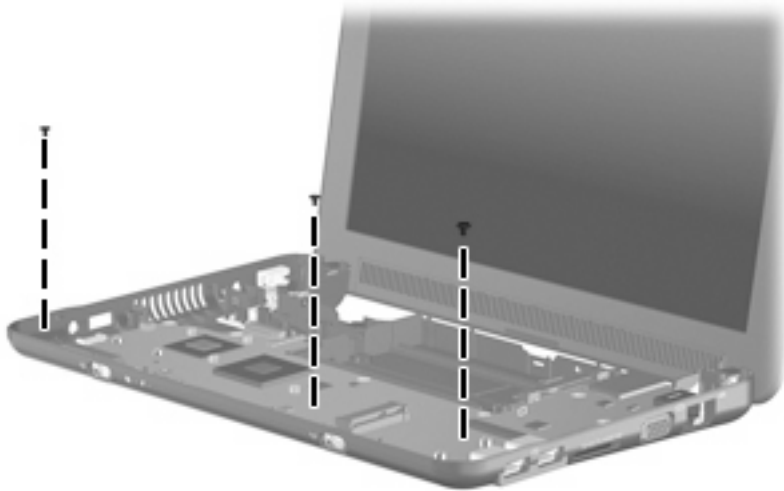

**Where used:** Three screws that secure the system board to the base enclosure

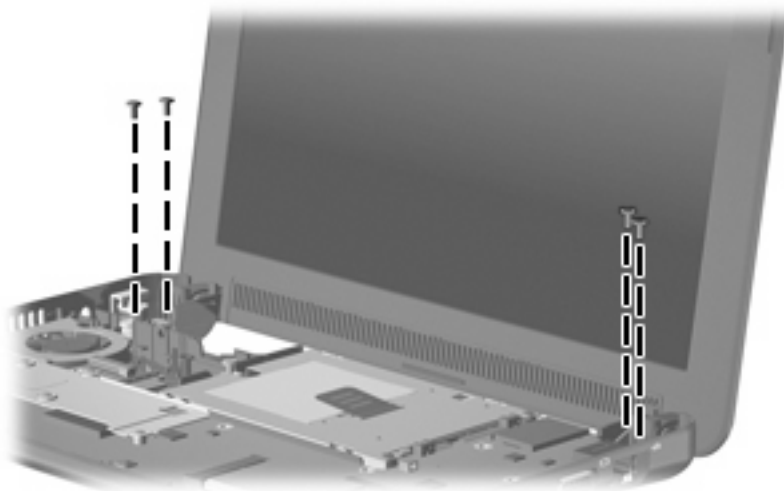

**Where used:** Four screws that secure the display assembly to the base enclosure

## Phillips PM2.5×7.0 screw

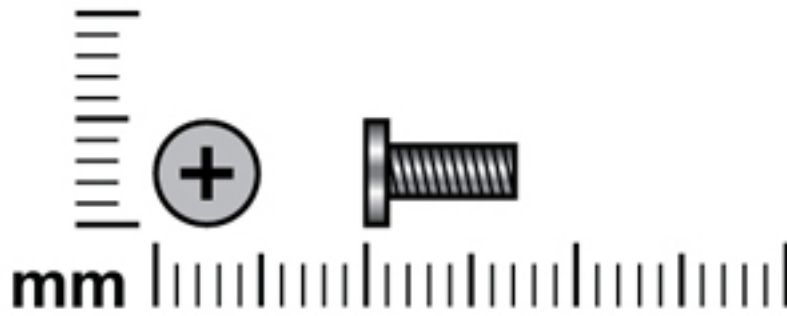

Color	Quantity	Length	Thread	Head diameter
Black	12	7.0 mm	2.5 mm	4.0 mm



**Where used:** Four screws that secure the top cover to the base enclosure

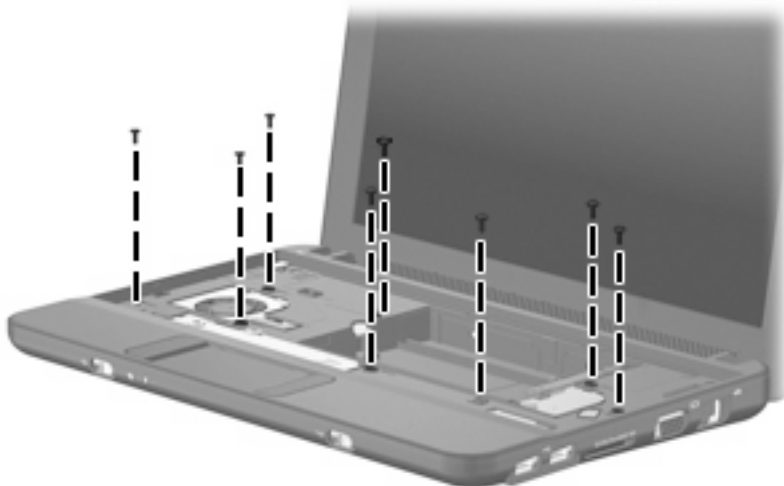

**Where used:** Eight screws that secure the top cover to the base enclosure

## Phillips PM2.5×10.0 captive screw

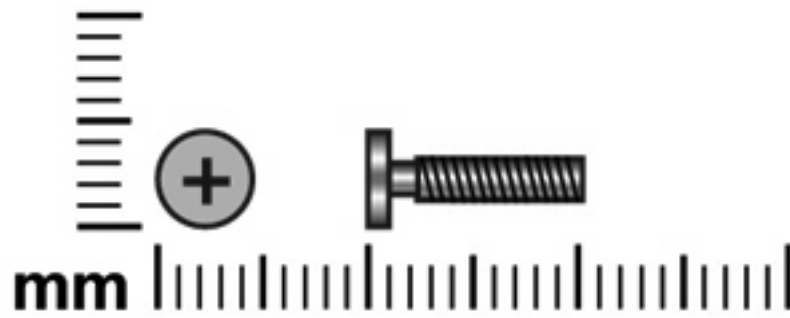

Color	Quantity	Length	Thread	Head diameter
Black	1	10.0 mm	2.5 mm	4.0 mm

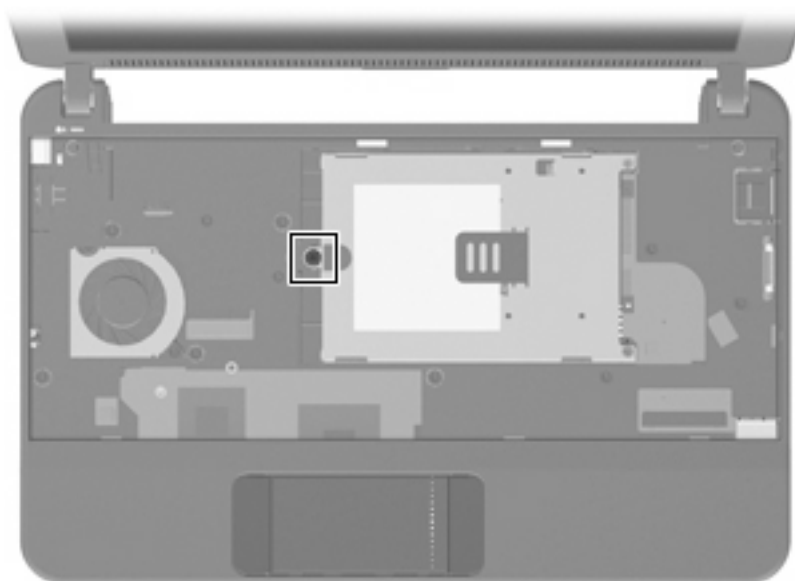

**Where used:** One captive screw, with a C-clip, that secures the hard drive or solid-state drive bracket to the system board

## Phillips PM3.0×4.0 screw

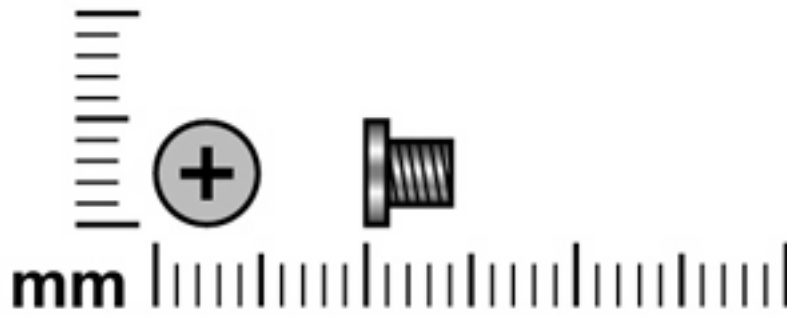

Color	Quantity	Length	Thread	Head diameter
Black	4	4.0 mm	3.0 mm	4.0 mm

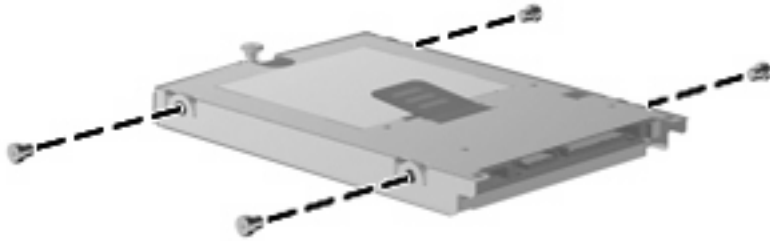

**Where used:** Four screws that secure the hard drive bracket to the hard drive

---

## 8 Backup and recovery

Select the section in this chapter that applies to the operating system installed on your computer.

# Mobile Mi backup and recovery

Use the instructions in this section if Mobile Mi is installed on your computer.

To protect your information, back up your files and folders. Then if the system fails, you can restore your important files from copies. You can also use the options listed in this section to restore the operating system and programs that were installed at the factory.

## Backing up your information

Successful recovery after a system failure depends on whether you have completely backed up your files. You should back up your files on a regular basis to maintain up-to-date files.

You can back up important personal files and folders to the Mini Mobile Drive (select models only), to an external hard drive, or to a USB flash drive (purchased separately).

## When to back up

- On a regular basis
- Before the system is repaired or restored
- Before you add or modify hardware or software

## Restoring your information

In case of system failure or instability, you can restore the operating system and programs installed at the factory.

△ **CAUTION:** The restore process reformats hard drive, completely erasing all information. All the files you have created and any software installed on the device are permanently removed. The restore process reinstalls the original operating system, software, and drivers. Software, drivers, and updates not installed with the factory image must be reinstalled using Update Manager.

The device provides the following restore options:

- System Restore (installed on the device): You can use the System Restore utility to restore the original operating system and programs.
- HP Mi Restore Image Creator (USB flash drive): If you are unable to boot (start up) the device, and if you are unable to use System Restore, you can use another computer to download the HP Mi Restore Image Creator utility and create a bootable USB flash drive (purchased separately). You can then use the USB flash drive to install the HP Mi recovery image and programs on your device.

Note the following before beginning the restore process:

- The device must be connected to AC power during the restore process.
- The restore process may take several hours to complete.
- If possible, all personal files should be backed up.



## Using System Restore

 **NOTE:** System Restore is the recommended option to restore the original operating system.

To restore the original operating system and programs using the System Restore utility that is installed on the device, follow these steps:

1. Turn on or restart the device, and then press the **esc** key repeatedly while the “F10 = BIOS Setup Options” message is displayed in the lower-left corner of the screen.

The “System Restore” page opens.

2. Use the arrow keys to select **System Restore**, and then press **enter**.
3. Follow the on-screen instructions to restore the system.

## Using HP Mi Restore Image Creator

 **NOTE:** Use HP Mi Restore Image Creator if you are unable to boot (start up) the device, and if you are unable to use System Restore.

You will need the following before you begin this restore process:

- A 2-GB (minimum) USB flash drive (purchased separately)

 **NOTE:** This USB flash drive should have bootable capability. Refer to the USB flash drive manufacturer for additional information.

- An additional computer running either a Windows® or Linux operating system

To perform this restore option, you download the HP Mi Restore Image Creator utility and Mini operating system onto another computer and then transfer the necessary files to the USB flash drive. The drive can then be used to reboot your device and restore the system.

Follow the specific operating system instructions in this section to restore your system.

 **CAUTION:** The restore process reformats and completely erases the hard drive on the Mini. All the files you have created and any software installed on the device are permanently removed. The restore process reinstalls the original operating system, software, and drivers. Software, drivers, and updates not installed with the factory image must be reinstalled using Update Manager.

## Restoring using a Windows computer

To download the files to a computer running a Windows operating system and then restore your device, follow these steps:

1. From your Windows computer, go to <http://www.hp.com>.
2. Select the **Support & Drivers** tab.
3. Under “Step 1: Start by selecting a task,” select **Download drivers and software (and firmware)**.
4. Under “Step 2: Enter a product name / number,” type the part number/product number (p/n) of your Mini, and then select **Go**.

 **NOTE:** The p/n is located on the service tag affixed to the bottom of your Mini.

5. Under “Which operating system is used with your product?” select **HP Mi** or **Linux**.

6. Select **HP Mi Restore Image Creator (for Windows)**.
7. Select **Download only**.
8. Save **ImageCreator.msi** to the Windows computer.
9. Double-click **ImageCreator.msi** and follow the on-screen instructions to install HP Mi Restore Image Creator.
10. Insert the USB flash drive into a USB port on the Windows computer.

---

△ **CAUTION:** The restore process reformats and completely erases the USB flash drive. All the files on the USB flash drive are permanently removed.

---

11. Launch **HP Mi Restore Image Creator** from the Start menu.
12. Select **Download HP Mini recovery image**.
13. Select the target USB flash drive, and then select **Start** to download the latest Mini recovery image from the HP Web site.

The recovery image will be downloaded and saved to the Windows computer and then written to the USB flash drive.

14. When the download and write processes are complete, remove the USB flash drive.
15. Insert the USB flash drive into a USB port on your Mini.
16. Change the boot order by turning on or restarting the device, and then pressing **f9** repeatedly while the “F9 = Change Boot Device Order” message is displayed in the lower-left corner of the screen.
17. Use the arrow keys to select the USB flash drive, and then press **enter**.
18. Press **enter** again to begin restoring the device.
19. Follow the on-screen instructions to install the operating system and programs.
20. After the operating system and programs are installed, remove the USB flash drive.

---

📝 **NOTE:** After the operating system and programs are installed, the device automatically restarts. You are then prompted to set up your device.

---

21. Use Update Manager to reinstall any updates not installed with the factory image.
22. Restore your personal files.

---

📝 **NOTE:** After this process is complete, you can uninstall the HP Mi Restore Image Creator utility from the Windows computer and delete the downloaded recovery image from the USB flash drive. (The image must be deleted manually.)

---

### Restoring using a Linux computer

To download the files to a computer running a Linux operating system and then restore your device, follow these steps:

1. From your Linux computer, go to <http://www.hp.com>.
2. Select the **Support & Drivers** tab.

3. Under “Step 1: Start by selecting a task,” select **Download drivers and software (and firmware)** .
4. Under “Step 2: Enter a product name / number,” type the part number/product number (p/n) of your Mini, and then select **Go**.

---

 **NOTE:** The p/n is located on the service tag affixed to the bottom of your Mini.

---

5. Under “Which operating system is used with your product?” select **HP Mi** or **Linux** .
6. Select **HP Mi Restore Image Creator (for Linux)**.
7. Select **Download only**.
8. Save **liveusb-creator-ubuntu\_0.3.3netbook0dennis5\_all.deb** to the Linux computer.
9. Install **liveusb-creator-ubuntu\_0.3.3netbook0dennis5\_all.deb** on the Linux computer.
10. Insert the USB flash drive into a USB port on the Linux computer

---

△ **CAUTION:** The restore process reformats and completely erases the USB flash drive. All the files on the USB flash drive are permanently removed.

---

11. Open a terminal window and type the following command at the command prompt:

```
sudo liveusb-creator
```

12. Select **Download restore image/HP Mi Restore Image**.
13. Select the target USB flash drive, and then select **Start** to download the latest Mini recovery image from the HP Web site.

The recovery image will be downloaded and saved to the Linux computer, and then written to the USB flash drive.

14. When the download and write processes are complete, remove the USB flash drive.
15. Insert the USB flash drive into a USB port on your Mini.
16. Change the boot order by turning on or restarting the device, and then pressing **f9** repeatedly while the “F9 = Change Boot Device Order” message is displayed in the lower-left corner of the screen.
17. Use the arrow keys to select the USB flash drive, and then press **enter**.
18. Press **enter** again to begin restoring the device.
19. Follow the on-screen instructions to install the operating system and programs.
20. After the operating system and programs are installed, remove the USB flash drive.

---

 **NOTE:** After the operating system and programs are installed, the device automatically restarts. You are then prompted to set up your device.

---

21. Use Update Manager to reinstall any updates not installed with the factory image.
22. Restore your personal files.

---

 **NOTE:** After this process is complete, you can uninstall the HP Mi Restore Image Creator utility from the Linux computer and delete the downloaded recovery image from the USB flash drive. (The image must be deleted manually.)

---

## Windows 7 backup and recovery

Use the instructions in the section if Windows 7 is installed on your computer.

To protect your information, back up your files and folders. In case of system failure, you can use the backup files to restore your computer.

△ **CAUTION:** In the event of a hard drive failure, you cannot use your computer to access the Disaster Recovery utility. Therefore, HP recommends that you download the Disaster Recovery utility SoftPaq, and then extract it to a USB flash drive as soon as possible after software setup. For details, refer to “Downloading and extracting the Disaster Recovery utility” later in this chapter.

Depending on your computer model, you may have one of the following backup and recovery solutions:

- Roxio BackOnTrack
- HP Recovery Manager

📝 **NOTE:** For detailed information, perform a search for these topics in Help and Support.

### Backing up and recovering using Roxio BackOnTrack

Successful recovery after a system failure depends on whether you have completely backed up your files. If Roxio BackOnTrack is preinstalled on your computer, BackOnTrack allows you to create a backup of your computer image. You should create the initial backup immediately after software setup. As you add new software and data files, you should continue to back up your system on a regular basis to maintain a reasonably current backup.

Note the following guidelines when backing up your information:

- Store personal files in the Documents library and back up this folder regularly.
- Back up templates stored in their associated programs.
- Save customized settings in a window, toolbar, or menu bar by taking a screen shot of your settings. The screen shot can be a time-saver if you have to reset your preferences.

To copy the screen and paste it into a word-processing document, follow these steps:

1. Display the screen.
2. Copy the screen:
  - To copy the active window, press **alt+fn+prt sc**.
  - To copy the entire screen, press **fn+prt sc**.
3. Open a word-processing document, select **Edit>Paste**.
4. Save the document.

### Creating a copy of the hard drive

The *back up drive* function of BackOnTrack creates a Disaster Recovery Set that is an exact image of your hard drive data. You can back up the image to an external hard drive (purchased separately).

To create a Disaster Recovery Set using BackOnTrack, follow these steps:

---

 **NOTE:** Be sure that the computer is connected to AC power before you start the backup process.

---

1. Select **Start>All Programs> Roxio**.
2. Select **BackOnTrack>BackOnTrack Home>Disaster Recovery**.
3. Select **Backup drive**.
4. Select a drive to back up.
5. Add a comment to describe the backup.

 **NOTE:** Comments are optional, but adding comments can help you remember the purpose of the backup. The date and list of drives being backed up are automatically included in the description.

---

6. Select a destination for the Disaster Recovery Set.

 **NOTE:** The destination cannot be a network drive.

---

7. Select the action button at the bottom-right of the computer screen.
8. Follow the on-screen instructions.

## Performing a recovery

In case of system failure or instability, the computer provides the following ways to recover your files:

- **BackOnTrack Disaster Recovery utility:** You can use Disaster Recovery to recover your hard drive image (including your files, programs, and operating system) after a hard drive failure.
- **BackOnTrack Instant Restore utility:** You can use Instant Restore to quickly restore your computer to a working state if a software-related problem occurs. The Instant Restore utility automatically creates working states periodically. You can also define a working state by saving the current computer state manually.

 **NOTE:** For more information about computer system states, refer to the BackOnTrack software help.

---

## Using the Disaster Recovery utility

 **NOTE:** To perform a recovery with Disaster Recovery, you need a USB flash drive (purchased separately). For optimum performance, the capacity of the drive should be no larger than 2 GB.

Disaster Recovery recovers data from a Disaster Recovery Set that you previously created with Roxio BackOnTrack. Disaster Recovery is available from the HP Web site in a compressed file called a *SoftPaq*.

 **NOTE:** Running the SoftPaq makes the USB drive bootable.

 **CAUTION:** Before performing a disaster recovery, you must download the Disaster Recovery utility and extract it to a USB flash drive.

---

## Downloading and extracting the Disaster Recovery utility

To download and extract Disaster Recovery, follow these steps:

1. Connect a bootable USB flash drive or external drive to a USB port on your computer.
2. Open your Web browser, go to <http://www.hp.com/support>, and select your country or region.

3. Enter the SoftPaq number `SP42226` in the **Search** box, press **enter**, and then follow the on-screen instructions.
4. Select **Download only** to save the file to your computer.
5. When prompted, select **Save**, and then select the external drive from the list of storage locations.
6. After the file is downloaded, navigate to the USB flash drive or external drive, and then double-click the SoftPaq file to format the USB flash drive and extract the Disaster Recovery files.
7. If prompted to do so, restart your computer after the installation is complete.

### Restoring your hard drive image

To restore your hard drive image using Disaster Recovery, follow these steps:

1. Connect the external hard drive containing the Disaster Recovery Set to your computer.
2. Connect the bootable USB flash drive containing the extracted Disaster Recovery utility to a USB port on your computer.
3. Change the boot device order by turning on or restarting the computer, and then press **f9**.
4. Use the arrow keys to select the USB flash drive, and then press **enter**.
5. At the Roxio BackOnTrack Disaster Recovery screen, select **Disaster Recovery>Next**.
6. Browse to the external hard drive containing the Disaster Recovery Set, and then select **Next**.
7. Select **Next** to proceed with the recovery.

---

 **NOTE:** This process may take several minutes.

---

8. After a message on the screen reports a successful recovery, select **Finish**.

### Using the Instant Restore utility

You can restore your computer from Windows when the operating system is functioning. If the operating system is not functioning, you can also access the utility by restarting your computer.

---

 **NOTE:** For more information about the Instant Restore utility, refer to the BackOnTrack software Help.

---

### Using the Instant Restore utility when the operating system is functioning

To recover information when the operating system is functioning properly, follow these steps:

1. Save and close all open documents and close any open programs.
2. Select **Start>All Programs>Roxio**.
3. Select **BackOnTrack>BackOnTrack Home>Instant Restore**.
4. Select **Restore State**, and then select a restore state.
5. Select the action button in the bottom-right corner of the computer screen.
6. Select **Yes** to confirm your selected restore state.

When the restore process is complete, the computer restarts and a notification message is displayed.

## Using the Instant Restore utility when the operating system is not functioning

To recover information when the operating system is not functioning, follow these steps:

1. Restart the computer.  

---

 **NOTE:** If the operating system has stopped responding and the computer screen is blue, restart the computer by turning the power switch off and then on.

---
2. When the computer logo (HP or Compaq) is displayed on the screen, press the **F6** button repeatedly until the Windows status bar is displayed.
3. When the Roxio BackOnTrack screen is displayed, follow the on-screen instructions.

## Using Windows Backup and Restore

To create a backup using Windows Backup and Restore, follow these steps:

---

 **NOTE:** Be sure that the computer is connected to AC power before you start the backup process.

---

**NOTE:** The backup process may take over an hour, depending on file size and the speed of the computer.

---

1. Select **Start>All Programs>Maintenance>Backup and Restore**.
2. Follow the on-screen instructions to set up and create a backup.

---

 **NOTE:** Windows includes the User Account Control feature to improve the security of your computer. You may be prompted for your permission or password for tasks such as installing software, running utilities, or changing Windows settings. Refer to Help and Support for more information.

---

## Using system restore points

When you back up your system, you are creating a system restore point. A system restore point allows you to save and name a snapshot of your hard drive at a specific point in time. You can then revert back to that point if you want to reverse subsequent changes made to your system.

---

 **NOTE:** Recovering to an earlier restore point does not affect data files saved or e-mails created since the last restore point.

---

You also can create additional restore points to provide increased protection for your system files and settings.

## When to create restore points

- Before you add or extensively modify software or hardware.
- Periodically, whenever the system is performing optimally.

---

 **NOTE:** If you revert to a restore point and then change your mind, you can reverse the restoration.

---

## Creating a system restore point

1. Select **Start>Control Panel>System and Security>System**.
2. In the left pane, select **System protection**.

3. Select the **System Protection** tab.
4. Under **Protection Settings**, select the disk for which you want to create a restore point.
5. Select **Create**.
6. Follow the on-screen instructions.

## Restoring to a previous date and time

To revert to a restore point (created at a previous date and time) when the computer was functioning optimally, follow these steps:

1. Select **Start>Control Panel>System and Security>System**.
2. In the left pane, select **System protection**.
3. Select the **System Protection** tab.
4. Select **System Restore**.
5. Follow the on-screen instructions.

## Backing up and recovering using HP Recovery Manager

If your computer includes HP Recovery Manager, tools provided by the operating system and by HP Recovery Manager software are designed to help you with the following tasks for safeguarding your information and restoring it in case of a system failure:

- Backing up your information
- Creating a set of recovery discs
- Creating system restore points
- Recovering a program or driver
- Performing a full system recovery

## Backing up your information

As you add new software and data files, you should back up your system on a regular basis to maintain a reasonably current backup. Back up your system at the following times:

- At regularly scheduled times

---

 **NOTE:** Set reminders to back up your information periodically.

---

- Before the computer is repaired or restored
- Before you add or modify hardware or software

Note the following when backing up:

- Create system restore points using the Windows System Restore feature, and periodically copy them to a disc.
- Store personal files in the Documents library, and periodically back up this folder.
- Back up templates stored in their associated programs.



- You can back up your information to an optional external hard drive, a network drive, or discs.
- When backing up to discs, use any of the following types of discs (purchased separately): CD-R, CD-RW, DVD+R, DVD-R, or DVD±RW. The discs you use depend on the type of optical drive you are using.

---

 **NOTE:** DVDs store more information than CDs, so using them for backup reduces the number of recovery discs required.

---

- When backing up to discs, number each disc before inserting it into an optical drive.
- Save the customized settings in a window, toolbar, or menu bar by taking a screen shot of the settings. The screen shot can be a time-saver if you have to reset your preferences.

To copy the screen and paste the image into a word-processing document:

1. Display the screen.
2. Copy the screen:
  - To copy only the active window, press **alt+prt sc**.
  - To copy the entire screen, press **prt sc**.
3. Open a word-processing document, select **Edit> Paste**.
4. Save the document.

## Creating a set of recovery discs

HP recommends that you create recovery discs to be sure that you can restore your system to its original factory state if you experience serious system failure or instability. Create these discs after setting up the computer for the first time.

---

 **NOTE:** This task will require an optional external or shared optical drive.

---

Handle these discs carefully and keep them in a safe place. The software allows the creation of only one set of recovery discs.

Note the following guidelines before creating recovery discs:

- You will need high-quality DVD-R, DVD+R, BD-R (writable Blu-ray), or CD-R discs. All these discs are purchased separately. DVDs have a larger storage capacity than CDs. If you use CDs, up to 20 discs may be required, whereas only a few DVDs are required.

---

 **NOTE:** Double-layer discs and read-write discs—such as CD-RW, DVD±RW, and BD-RE (rewritable Blu-ray) discs—are not compatible with the Recovery Manager software.

---

- The computer must be connected to AC power during this process.
- Only one set of recovery discs can be created per computer.
- Number each disc before inserting it into an optical drive.
- If necessary, you can exit the program before you have finished creating the recovery discs. The next time you open Recovery Manager, you will be prompted to continue the disc creation process.

To create a set of recovery discs:

1. Select **Start>All Programs>Recovery Manager>Recovery Disc Creation**.
2. Follow the on-screen instructions.

## Performing a recovery

 **NOTE:** You can recover only files that you have previously backed up. HP recommends that you use Recovery Manager to create a set of recovery discs (entire drive backup) as soon as you set up your computer.

---

Recovery Manager software allows you to repair or restore the system if you experience system failure or instability. Recovery Manager works from recovery discs that you create or from a dedicated recovery partition (select models only) on the hard drive. However, computers that include a solid-state drive (SSD) may not have a recovery partition. If that is the case, recovery discs have been included with your computer. Use these discs to recover your operating system and software.

 **NOTE:** Windows has its own built-in repair features, such as System Restore. If you have not already tried these features, try them before using Recovery Manager. For more information on these built-in repair features, select **Start>Help and Support**.

**NOTE:** Recovery Manager recovers only the software that was preinstalled at the factory. Software not provided with this computer must be downloaded from the manufacturer's Web site or reinstalled from the disc provided by the manufacturer.

---

## Recovering using the recovery discs

To restore the system from the recovery discs:

1. Back up all personal files.
2. Insert the first recovery disc into an optional optical drive, and restart the computer.
3. Follow the on-screen instructions.

## Recovering using the partition on the hard drive (select models only)

On some models, you can perform a recovery from the partition on the hard drive, which is accessed by pressing either the Start button or **f11**. This restores the computer to its factory condition.

 **NOTE:** Computers with an SSD may not have a recovery partition. If the computer does not have a recovery partition, you will not be able to recover using this procedure. Recovery discs have been included for computers that do not have a partition. Use these discs to recover your operating system and software.

---

To restore the system from the partition, follow these steps:

1. Access Recovery Manager in either of the following ways:  
Select **Start>All Programs>Recovery Manager>Recovery Manager**.  
– or –
  - a. Turn on or restart the computer.
  - b. Press **f11** while the “Press f11 for recovery message is displayed on the screen.

 **NOTE:** It may take several minutes for Recovery Manager to load.

---

2. In the Recovery Manager window, select **System Recovery**.
3. Follow the on-screen instructions.

# Windows Vista backup and recovery

Use the instructions in this section if Windows Vista is installed on your computer.

## Backing up your information

Recovery after a system failure is as complete as your most current backup. You should create your initial backup immediately after software setup. As you add new software and data files, you should continue to back up your system on a regular basis to maintain a reasonably current backup.

You can back up your information to an optional external hard drive, a network drive, or discs.

Note the following when backing up:

- Store personal files in the Documents folder, and back it up regularly.
- Back up templates that are stored in their associated programs.
- Save customized settings that appear in a window, toolbar, or menu bar by taking a screen shot of your settings. The screen shot can be a time-saver if you have to reset your preferences.

To create a screen shot:

1. Display the screen you want to save.
2. Copy the screen image:

To copy only the active window, press **alt+fn+prt sc**.

To copy the entire screen, press **fn+prt sc**.

3. Open a word-processing document, and then select **Edit > Paste**.

The screen image is added to the document.

4. Save the document.

- When backing up to discs, use any of the following types of discs (purchased separately): CD-R, CD-RW, DVD+R, DVD+R DL, DVD-R, DVD-R DL, or DVD±RW. The discs you use will depend on the type of optical drive installed in your computer.

---

 **NOTE:** DVDs and DVDs with double-layer (DL) support store more information than CDs, so using them for backup reduces the number of recovery discs required.

---

- When backing up to discs, number each disc before inserting it into the optical drive of the computer.

To create a backup using Backup and Restore Center, follow these steps:

 **NOTE:** Be sure that the computer is connected to AC power before you start the backup process.

**NOTE:** The backup process may take over an hour, depending on file size and the speed of the computer.

---

1. Select **Start > All Programs > Maintenance > Backup and Restore Center**.
2. Follow the on-screen instructions to back up your entire computer (select models only) or your files.

---

 **NOTE:** Windows® includes the User Account Control feature to improve the security of your computer. You may be prompted for your permission or password for tasks such as installing software, running utilities, or changing Windows settings. Refer to Help and Support for more information.

---

## Performing a recovery

In case of system failure or instability, the computer provides the following tools to recover your files:

- **Windows recovery tools:** You can use the Backup and Restore Center to recover information you have previously backed up. You can also use Windows Startup Repair to fix problems that might prevent Windows from starting correctly.
- **f11 recovery tools:** You can use the **f11** recovery tools to recover your original hard drive image. The image includes the Windows operating system and software programs installed at the factory.

---

 **NOTE:** If you are unable to boot (start up) your computer, you must purchase a Windows Vista® operating system DVD to reboot the computer and repair the operating system. For additional information, refer to the “Using a Windows Vista operating system DVD (purchased separately)” section in this guide.

---

## Using the Windows recovery tools

To recover information you previously backed up, follow these steps:

1. Select **Start > All Programs > Maintenance > Backup and Restore Center**.
2. Follow the on-screen instructions to recover your entire computer (select models only) or your files.

 **NOTE:** Windows includes the User Account Control feature to improve the security of your computer. You may be prompted for your permission or password for tasks such as installing software, running utilities, or changing Windows settings. Refer to Help and Support for more information.

---

To recover your information using Startup Repair, follow these steps:

 **CAUTION:** Using Startup Repair completely erases hard drive contents and reformats the hard drive. All files you have created and any software installed on the computer are permanently removed. When reformatting is complete, the recovery process restores the operating system, as well as the drivers, software, and utilities from the backup used for recovery.

---

1. If possible, back up all personal files.
2. If possible, check for the presence of the Windows partition and the HP Recovery partition. To find the partitions, select **Start > Computer**.

 **NOTE:** If the Windows partition and the HP Recovery partition have been deleted, you must recover your operating system and programs using the Windows Vista operating system DVD and the *Driver Recovery* disc (both purchased separately). For additional information, refer to the “Using a Windows Vista operating system DVD (purchased separately)” section in this guide.

---

3. Restart the computer, and then press **f8** before the Windows operating system loads.
4. Select **Repair your computer**.
5. Follow the on-screen instructions.

 **NOTE:** For additional information on recovering information using the Windows tools, perform a search for these topics in Help and Support.

---

## Using f11

- △ **CAUTION:** Using **f11** completely erases hard drive contents and reformats the hard drive. All files you have created and any software installed on the computer are permanently removed. The **f11** recovery tool reinstalls the operating system and HP programs and drivers that were installed at the factory. Software not installed at the factory must be reinstalled.

To recover the original hard drive image using **f11**, follow these steps:

1. If possible, back up all personal files.
2. If possible, check for the presence of the HP Recovery partition. To find the partition, select **Start > Computer**.

 **NOTE:** If the HP Recovery partition has been deleted, you must recover your operating system and programs using the Windows Vista operating system DVD and the *Driver Recovery* disc (both purchased separately). For additional information, refer to the “Using a Windows Vista operating system DVD (purchased separately)” section in this guide.

3. Turn on or restart the computer, and then press **esc** while the “Press the ESC key for Startup Menu” message is displayed at the bottom of the screen.
4. Press **f11** while the “Press <F11> for recovery” message is displayed on the screen.
5. Follow the on-screen instructions.

## Using a Windows Vista operating system DVD (purchased separately)

If you are unable to boot (start up) your computer, you must purchase a Windows Vista operating system DVD to reboot the computer and repair the operating system. Make sure that your most recent backup (stored on discs or on an external drive) is easily accessible. To order a Windows Vista operating system DVD, go to <http://www.hp.com/support>, select your country or region, and follow the on-screen instructions. You can also order the DVD by calling technical support. For contact information, refer to the *Worldwide Telephone Numbers* booklet included with the computer.

- △ **CAUTION:** Using a Windows Vista operating system DVD completely erases hard drive contents and reformats the hard drive. All files you have created and any software installed on the computer are permanently removed. When reformatting is complete, the recovery process helps you restore the operating system, as well as drivers, software, and utilities.

To initiate recovery using a Windows Vista operating system DVD, follow these steps:

 **NOTE:** This process takes several minutes.

1. If possible, back up all personal files.
2. Restart the computer, and then insert the Windows Vista operating system DVD into the optical drive before the Windows operating system loads.
3. When prompted, press any keyboard key.
4. Follow the on-screen instructions.
5. Select **Next**.
6. Select **Repair your computer**.
7. Follow the on-screen instructions.

# Windows XP backup and recovery

Use the instructions in this section if Windows XP is installed on your computer.

To protect your information, use the Windows® Backup utility (select models only) to back up files and folders or create recovery points. In case of system failure, you can use the backup files to restore your computer.

Windows provides the following options:

- Backing up individual files and folders
- Backing up all files and folders
- Scheduling automatic backups
- Creating recovery points
- Recovering information

---

 **NOTE:** For detailed instructions, perform a search for these topics in Help and Support.

**NOTE:** In case of system instability, HP recommends that you print the recovery procedures and save them for later use.

---

## Backing up your information

Recovery after a system failure is as complete as your most current backup. You should create your initial backup immediately after software setup. As you add new software and data files, you should continue to back up your system on a regular basis to maintain a reasonably current backup.

You can back up individual files or folders to an optional external hard drive or to a network drive.

Note the following when backing up:

- Store personal files in the My Documents folder, and back it up periodically.
- Back up templates stored in their associated programs.
- Save customized settings that appear in a window, toolbar, or menu bar by taking a screen shot of your settings. The screen shot can be a time saver if you have to reset your preferences.

To copy the screen and paste it into a word-processing document:

- a. Display the screen you want to save.
- b. Copy the screen image:
  - To copy only the active window, press **alt+fn+prt sc**.
  - To copy the entire screen, press **fn+prt sc**.
- c. Open a word-processing document, select **Edit > Paste**.
  - The screen image is added to the document.
- d. Save the document.

To create a backup using the Windows Backup utility (select models only), follow these steps:



---

 **NOTE:** Be sure that the computer is connected to AC power before you start the backup process.

**NOTE:** The backup process may take over an hour, depending on file size and the speed of the computer.

---

1. Select **Start > All Programs > Accessories > System Tools > Backup**.
2. Follow the on-screen instructions.

## Performing a recovery

In case of system failure or instability, the computer provides the following tools to recover your files:

- Windows recovery tools (select models only): You can use the Windows Backup utility to recover information you have previously backed up.
- *Operating System* and *Driver Recovery* discs (included with your computer): You can use the discs to recover your operating system and programs installed at the factory.

## Recovering your information

To recover information you previously backed up, follow these steps:

1. If possible, back up all personal files.
2. Select **Start > All Programs > Accessories > System Tools > Backup**.

The Backup or Restore Wizard opens.

3. Select **Restore files and settings >Next**.
4. Follow the on-screen instructions.

---

 **NOTE:** For additional information on initiating a recovery in Windows, perform a search for this topic in Help and Support.

---

## Recovering the operating system and programs

 **CAUTION:** The recovery process reformats and completely erases the hard drive. All files you have created and any software installed on the computer are permanently removed. The recovery process reinstalls the original operating system, software, and drivers. Software, drivers, and updates not installed by HP must be manually reinstalled.

---

To recover your operating system and programs, follow these steps:

1. If possible, back up all personal files.
2. Insert the *Operating System* disc into the optical drive.
3. Shut down the computer.
4. Turn on the computer.
5. Follow the on-screen instructions to install the operating system.
6. After the operating system is installed, remove the *Operating System* disc and insert the *Driver Recovery* disc.
7. Follow the on-screen instructions to install the drivers and programs.

---

## 9 Connector pin assignments

### Audio-in (microphone)

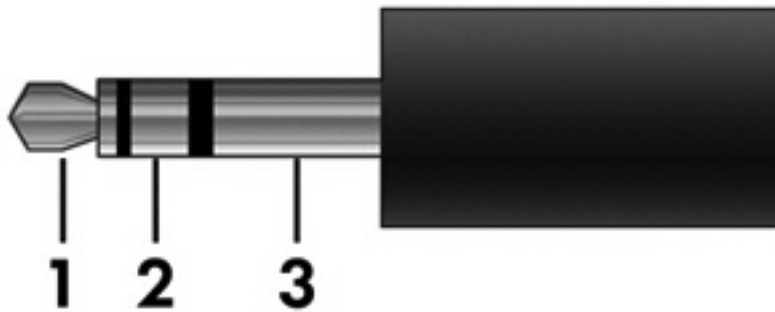

Pin	Signal
1	Audio signal in
2	Audio signal in
3	Ground

## Audio-out (headphone)

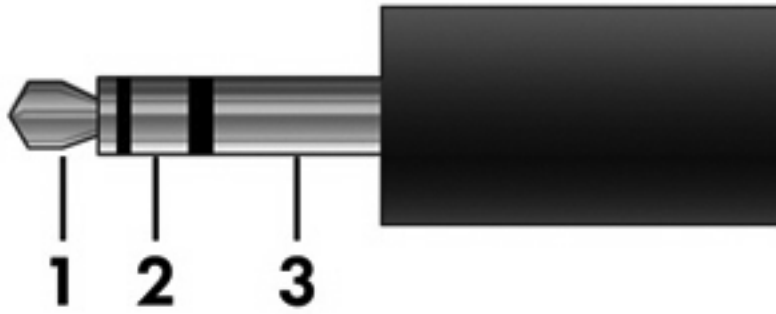

Pin	Signal
1	Audio out, left channel
2	Audio out, right channel
3	Ground

## External monitor

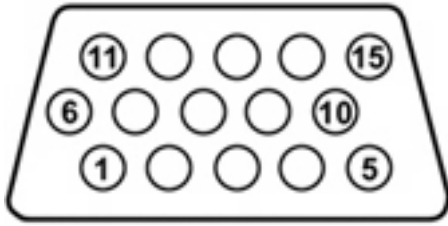

Pin	Signal
1	Red analog
2	Green analog
3	Blue analog
4	Not connected
5	Ground
6	Ground analog
7	Ground analog
8	Ground analog
9	+5 VDC
10	Ground
11	Monitor detect
12	DDC 2B data
13	Horizontal sync
14	Vertical sync
15	DDC 2B clock

## RJ-45 (network)

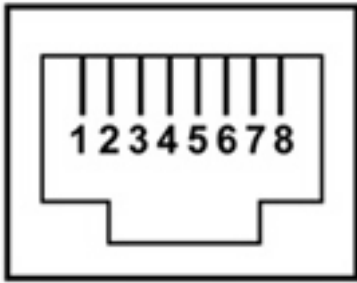

Pin	Signal
1	Transmit +
2	Transmit -
3	Receive +
4	Unused
5	Unused
6	Receive -
7	Unused
8	Unused

## Universal Serial Bus

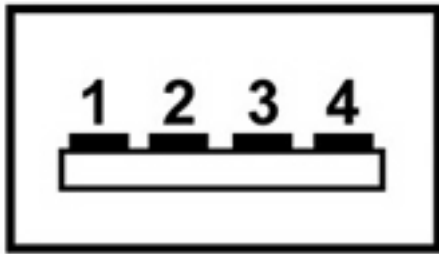

Pin	Signal
1	+5 VDC
2	Data -
3	Data +
4	Ground

---

# 10 Power cord set requirements

The wide range input feature of the device permits it to operate from any line voltage from 100 to 120 volts AC or from 220 to 240 volts AC.

The 3-conductor power cord set included with the device meets the requirements for use in the country or region where the equipment is purchased.

Power cord sets for use in other countries and regions must meet the requirements of the country or region where the device is used.

## Requirements for all countries and regions

The requirements listed below are applicable to all countries and regions:

- The length of the power cord set must be at least 1.5 m (5.0 ft) and no more than 2.0 m (6.5 ft).
- All power cord sets must be approved by an acceptable accredited agency responsible for evaluation in the country or region where the power cord set will be used.
- The power cord sets must have a minimum current capacity of 10 amps and a nominal voltage rating of 125 or 250 V AC, as required by the power system of each country or region.
- The appliance coupler must meet the mechanical configuration of an EN 60 320/IEC 320 Standard Sheet C13 connector for mating with the appliance inlet on the back of the device.

## Requirements for specific countries and regions

Country/region	Accredited agency	Applicable note number
Australia	EANSW	1
Austria	OVE	1
Belgium	CEBC	1
Canada	CSA	2
Denmark	DEMKO	1
Finland	FIMKO	1
France	UTE	1
Germany	VDE	1
Italy	IMQ	1
Japan	METI	3
The Netherlands	KEMA	1
Norway	NEMKO	1
The People's Republic of China	CCC	5
South Korea	EK	4
Sweden	SEMKO	1
Switzerland	SEV	1
Taiwan	BSMI	4
The United Kingdom	BSI	1
The United States	UL	2

1. The flexible cord must be Type HO5VV-F, 3-conductor, 1.0-mm<sup>2</sup> conductor size. Power cord set fittings (appliance coupler and wall plug) must bear the certification mark of the agency responsible for evaluation in the country or region where it will be used.
2. The flexible cord must be Type SPT-3 or equivalent, No. 18 AWG, 3-conductor. The wall plug must be a two-pole grounding type with a NEMA 5-15P (15 A, 125 V) or NEMA 6-15P (15 A, 250 V) configuration.
3. The appliance coupler, flexible cord, and wall plug must bear a "T" mark and registration number in accordance with the Japanese Dentori Law. The flexible cord must be Type VCT or VCTF, 3-conductor, 1.00-mm<sup>2</sup> conductor size. The wall plug must be a two-pole grounding type with a Japanese Industrial Standard C8303 (7 A, 125 V) configuration.
4. The flexible cord must be Type RVV, 3-conductor, 0.75-mm<sup>2</sup> conductor size. Power cord set fittings (appliance coupler and wall plug) must bear the certification mark of the agency responsible for evaluation in the country or region where it will be used.
5. The flexible cord must be Type VCTF, 3-conductor, 0.75-mm<sup>2</sup> conductor size. Power cord set fittings (appliance coupler and wall plug) must bear the certification mark of the agency responsible for evaluation in the country or region where it will be used.



---

# 11 Recycling

## Battery

When a battery has reached the end of its useful life, do not dispose of the battery in general household waste. Follow the local laws and regulations in your area for computer battery disposal.

## Display

- 
- ⚠ **WARNING!** The backlight contains mercury. Exercise caution when removing and handling the backlight to avoid damaging this component and causing exposure to the mercury.
  - ⚠ **CAUTION:** The procedures in this chapter can result in damage to display components. The only components intended for recycling purposes are the liquid crystal display (LCD) panel and the backlight. When you remove these components, handle them carefully.
  - 📄 **NOTE: Materials Disposal.** This HP product contains mercury in the backlight in the display assembly that might require special handling at end-of-life. Disposal of mercury may be regulated because of environmental considerations. For disposal or recycling information, contact your local authorities, or see the Electronic Industries Alliance (EIA) Web site at <http://www.eiae.org>.
- 

This section provides disassembly instructions for the display assembly. The display assembly must be disassembled to gain access to the backlight **(1)** and the liquid crystal display (LCD) panel **(2)**.



- 
- 📄 **NOTE:** The procedures provided in this chapter are general disassembly instructions. Specific details, such as screw sizes, quantities, and locations, and component shapes and sizes, can vary from one computer model to another.
-

Perform the following steps to disassemble the display assembly:

1. Remove all screw covers (1) and screws (2) that secure the display bezel to the display assembly.

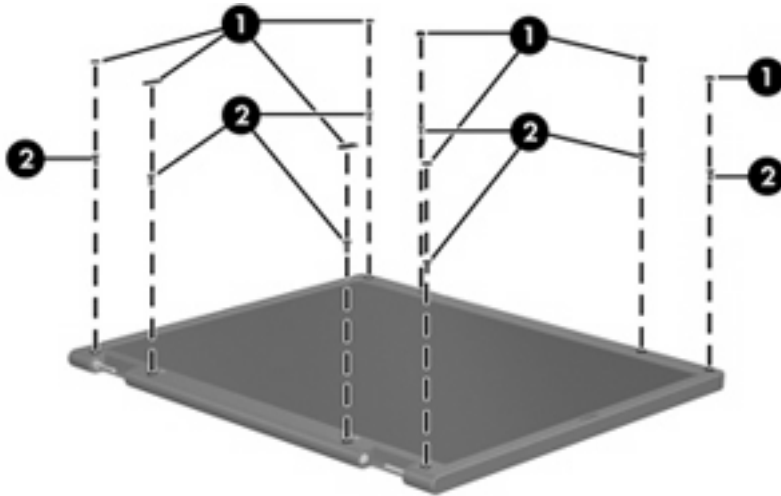

2. Lift up and out on the left and right inside edges (1) and the top and bottom inside edges (2) of the display bezel until the bezel disengages from the display assembly.
3. Remove the display bezel (3).

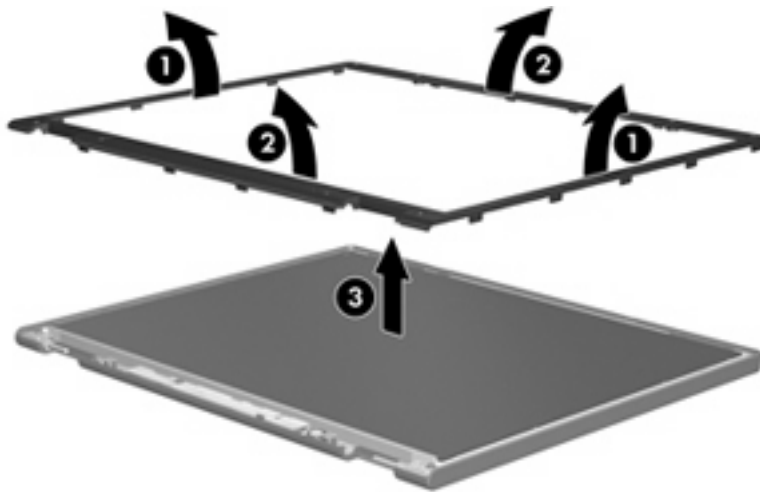

4. Disconnect all display panel cables (1) from the display inverter and remove the inverter (2).

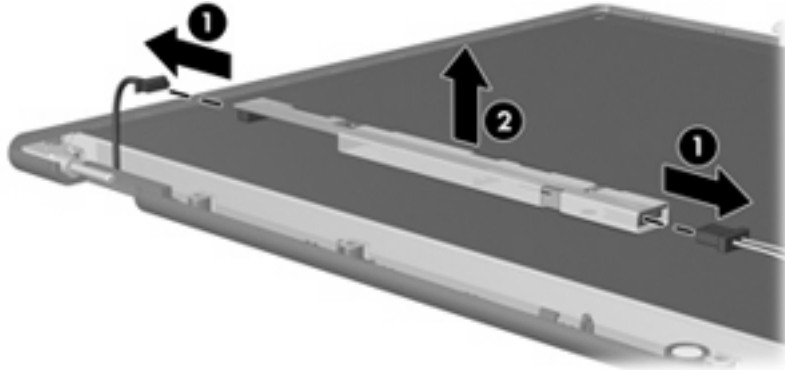

5. Remove all screws (1) that secure the display panel assembly to the display enclosure.
6. Remove the display panel assembly (2) from the display enclosure.

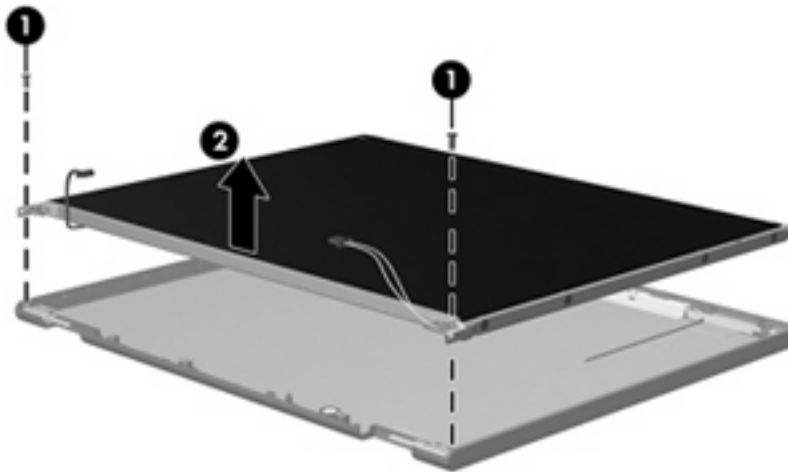

7. Turn the display panel assembly upside down.
8. Remove all screws that secure the display panel frame to the display panel.

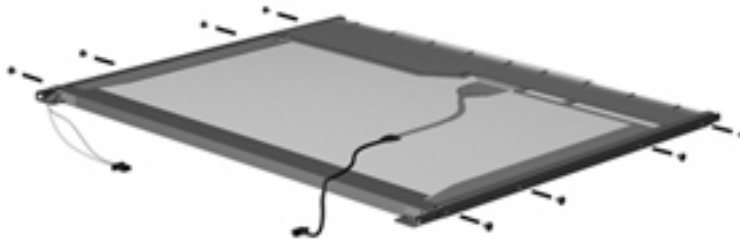

9. Use a sharp-edged tool to cut the tape (1) that secures the sides of the display panel to the display panel frame.

10. Remove the display panel frame (2) from the display panel.

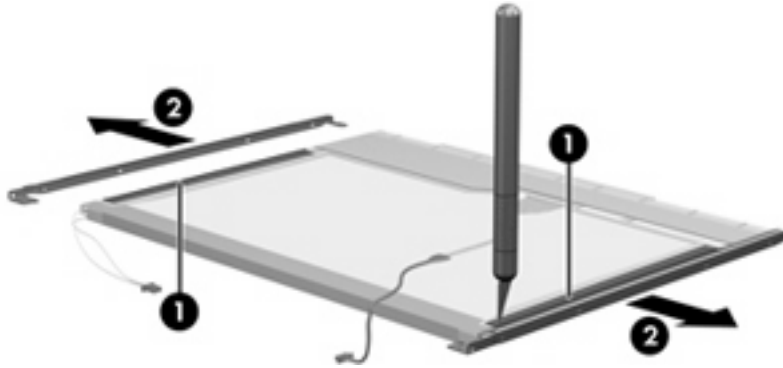

11. Remove the screws (1) that secure the backlight cover to the display panel.
12. Lift the top edge of the backlight cover (2) and swing it outward.

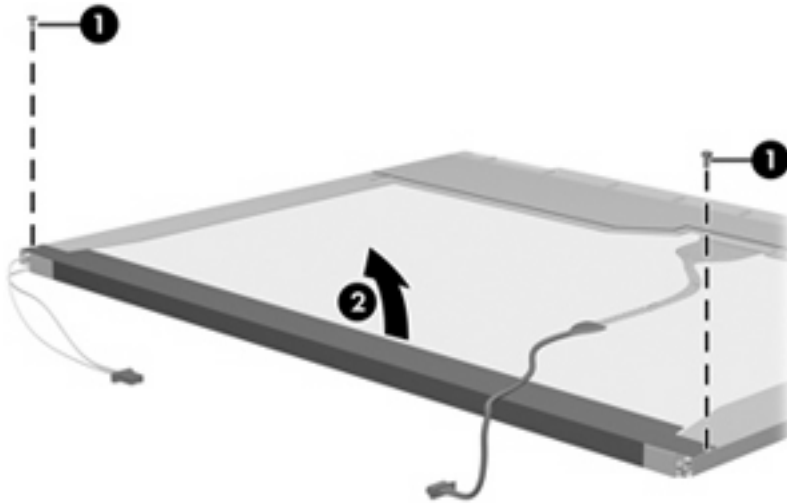

13. Remove the backlight cover.
14. Turn the display panel right-side up.

15. Remove the backlight cables (1) from the clip (2) in the display panel.

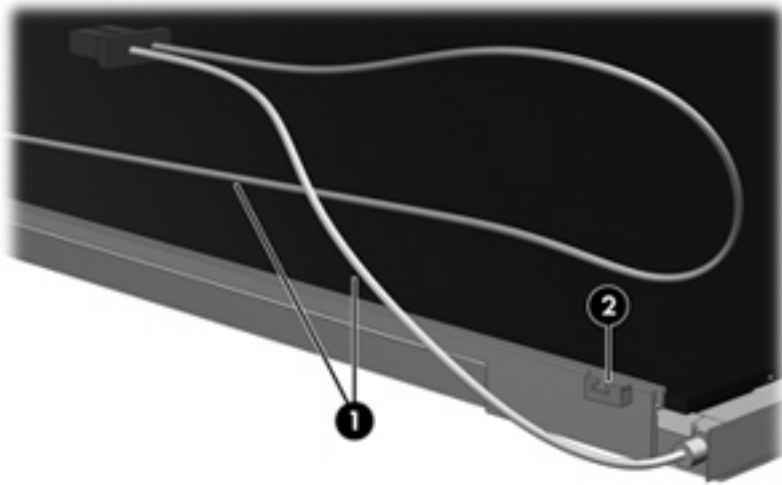

16. Turn the display panel upside down.

**⚠ WARNING!** The backlight contains mercury. Exercise caution when removing and handling the backlight to avoid damaging this component and causing exposure to the mercury.

17. Remove the backlight frame from the display panel.

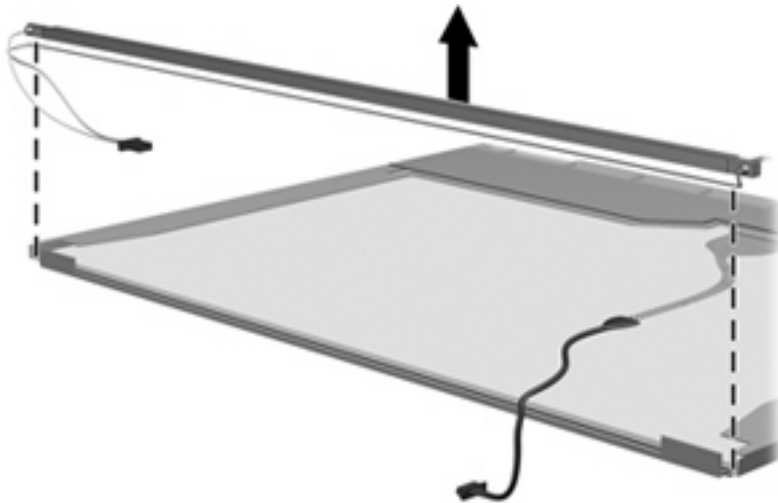

18. Remove the backlight from the backlight frame.

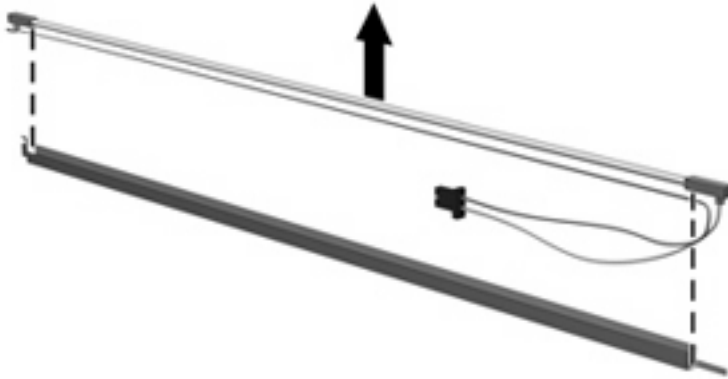

19. Disconnect the display panel cable (1) from the LCD panel.  
20. Remove the screws (2) that secure the LCD panel to the display rear panel.  
21. Release the LCD panel (3) from the display rear panel.  
22. Release the tape (4) that secures the LCD panel to the display rear panel.

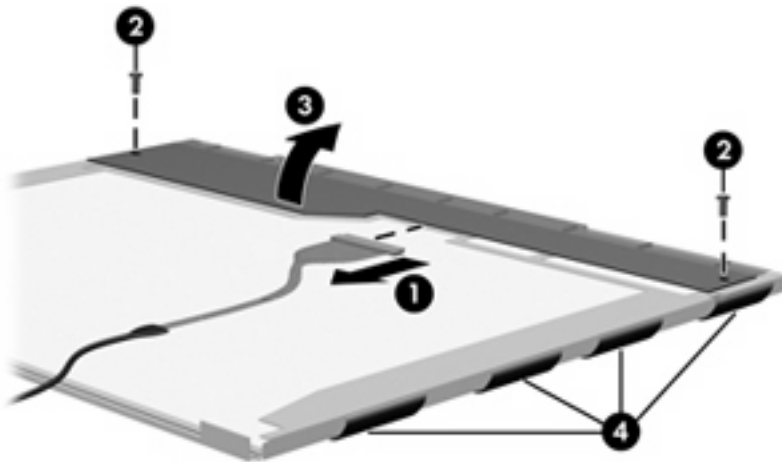

23. Remove the LCD panel.

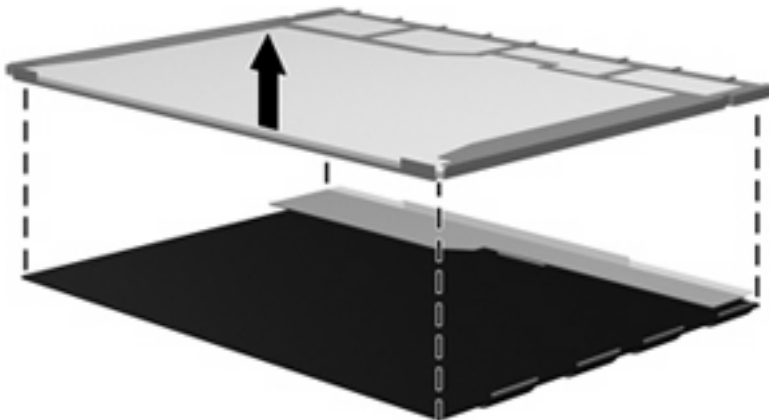

24. Recycle the LCD panel and backlight.

# Index

## A

AC adapter, spare part  
number 28  
administrator password 85  
antenna  
removal 82  
spare part number 25, 76  
antennas 15  
applications key, Windows 7  
audio, product description 2  
audio-in (microphone) jack 12  
audio-out (headphone) jack 12  
audio-in jack  
pin assignments 128  
audio-out jack  
pin assignments 129

## B

Backup and Restore Center 122  
base enclosure, spare part  
number 24  
battery  
removal 44  
spare part number 24, 44  
battery bay, identifying 14  
battery light 9  
battery release latches 14  
bay, battery 14  
boot options 85  
boot order 85  
buttons  
left TouchPad 5  
right TouchPad 5

## C

cables, service considerations 37  
caps lock light, identifying 6  
changing the Setup Utility  
language 83  
chipset, product description 1

compartments, memory  
module 14  
components  
bottom 14  
display 13  
front 9  
left-side 12  
right-side 11  
TouchPad 5  
connectors  
service considerations 37

## D

device feet  
locations 43  
spare part number 43  
device specifications 87  
Diagnostics menu 86  
Digital Media Slot, identifying 11  
discs  
Driver Recovery 127  
Operating System 127  
diskette drive  
precautions 38  
product description 2  
display assembly  
removal 75  
spare part number 17, 75  
display bezel  
illustrated 25, 75  
removal 78  
spare part number 25, 75  
Display Cable Kit, spare part  
number 25, 76  
display component recycling 135  
display enclosure  
illustrated 26, 76  
spare part number 26, 76  
Display Hinge Kit, spare part  
number 25, 76

display hinge, removal 80  
display panel  
illustrated 25, 76  
removal 79  
spare part number 25, 76  
Display Screw Kit, spare part  
number 26, 76  
display specifications 88, 89  
display switch, identifying 13  
displaying system information 84  
drive light, identifying 9  
Driver Recovery disc 127  
drives  
preventing damage 38  
drives, boot order 85

## E

earbuds 12  
electrostatic discharge 39  
Ethernet, product description 3  
exiting the Setup Utility 84  
external media cards, product  
description 3  
external monitor port  
pin assignments 130  
external monitor port,  
identifying 11

## F

f11 recovery 125  
fan  
removal 68  
spare part number 21, 68  
feet  
locations 43  
spare part number 43  
flash storage drive, product  
description 2  
fn key 7, 8  
function keys 7, 8

- G**
- graphics, product description 1
- grounding equipment and methods 41
- H**
- hard drive
  - precautions 38
  - product description 2
  - spare part number 21
  - specifications 90
- hard drive recovery 125
- hard drive self test 86
- headphone (audio-out) jack 12
- headphone jack
  - pin assignments 129
- headphones 12
- heat sink assembly
  - removal 70
  - spare part number 70
- hinge covers
  - illustrated 25, 75
  - spare part number 25, 75
- Home key 8
- HP Mi Restore Image Creator
  - identifying 110
  - using 111
- I**
- I/O address specifications 94
- internal display switch, identifying 13
- internal media cards, product description 3
- internal microphone, identifying 13
- interrupt specifications 93
- J**
- jacks
  - audio-in (microphone) 12
  - audio-out (headphone) 12
  - RJ-45 (network) 11
- K**
- keyboard
  - product description 3
  - removal 48
  - spare part number 18, 48
- keys
  - fn 7, 8
- function 7, 8
- Home 8
- Program Switcher 8
- Windows applications 7
- Windows logo 7
- L**
- language support 85
- latches, battery release 14
- left TouchPad button, identifying 5
- lights
  - battery 9
  - caps lock 6
  - drive 9
  - power 9
  - webcam 13
  - wireless 10
- M**
- Main menu 85
- mass storage device
  - product description 2
  - spare part number 21
- mass storage devices
  - illustrated 54
  - spare part numbers 54
- memory map specifications 96
- memory module
  - product description 2
  - removal 46
  - spare part number 24, 46
- memory module compartment cover
  - removal 46
- memory module compartment, identifying 14
- memory test 86
- microphone (audio-in) jack 12
- microphone assembly, spare part number 25, 76
- microphone jack
  - pin assignments 128
- model name 1
- modem, product description 3
- monitor port
  - pin assignments 130
- N**
- navigating in the Setup Utility 83
- network jack
  - pin assignments 131
- network jack, identifying 11
- O**
- Operating System disc 127
- operating system, product description 4
- optical drive, product description 2
- P**
- packing guidelines 40
- panels, product description 1
- passwords 85
- pin assignments
  - audio-in jack 128
  - audio-out jack 129
  - external monitor port 130
  - headphone jack 129
  - microphone jack 128
  - monitor port 130
  - network jack 131
  - RJ-45 jack 131
  - Universal Serial Bus (USB) port 132
- plastic parts 37
- pointing device
  - product description 3
- ports
  - product description 3
  - USB 11, 12
- power connector, identifying 12
- power cord
  - set requirements 133
  - spare part number 28
- power light, identifying 9
- power requirements, product description 4
- power switch, identifying 9
- power-on password 85
- Processor C4 State 85
- processor, product description 1
- product description
  - audio 2
  - chipset 1
  - diskette drive 2
  - Ethernet 3
  - external media cards 3
  - flash storage drive 2



- graphics 1
- hard drive 2
- internal media cards 3
- keyboard 3
- mass storage device 2
- memory module 2
- modem 3
- operating system 4
- optical drive 2
- panels 1
- pointing device 3
- ports 3
- power requirements 4
- processors 1
- product name 1
- security 4
- serviceability 4
- solid-state drive 2
- wireless 3
- product name 1
- Program Switcher key 8

**R**

- recovery partition 125
- release latches
  - battery 14
- removal/replacement
  - preliminaries 37
  - procedures 42
- restoring
  - HP Mi Restore Image Creator 111
  - System Restore 111
- restoring default settings 84
- restoring the hard drive 125
- right TouchPad button, identifying 5
- RJ-45 (network) jack, identifying 11
- RJ-45 jack
  - pin assignments 131
- RTC battery
  - removal 53
  - spare part number 23, 53
- Rubber Kit, spare part number 28

**S**

- Screw Kit
  - contents 97
  - spare part number 28

- screw listing 97
- security cable slot, identifying 12
- Security menu 85
- security, cable slot 12
- security, product description 4
- selecting in the Setup Utility 83
- serial number 16, 42
- service considerations 37
- service tag 16, 42
- serviceability, product description 4
- SIM
  - removal 45
- solid-state drive
  - product description 2
- solid-state drives
  - spare part number 21
- speaker assembly
  - illustrated 25, 76
  - removal 79
  - spare part number 25, 76
- speakers, identifying 13
- specifications
  - device 87
  - display 88, 89
  - hard drive 90
  - I/O addresses 94
  - interrupts 93
  - memory map 96
  - solid-state drive 91
  - system DMA 92
- static-shielding materials 41
- switches
  - power 9
  - wireless 10
- system board
  - removal 72
  - spare part number 23, 72
- System Configuration menu 85
- system DMA 92
- system information 85
- system memory map 96
- System Restore
  - identifying 110
  - using 111

**T**

- tools required 37

- top cover
  - removal 57
  - spare part number 21, 57
- TouchPad
  - buttons 5
  - identifying 5
- TouchPad scroll zone, identifying 5
- transporting guidelines 40

**U**

- USB board
  - removal 64
  - spare part number 64
- USB board, spare part number 21, 64
- USB port
  - pin assignments 132
- USB ports, identifying 11, 12

**V**

- vents, identifying 12, 14

**W**

- webcam light, identifying 13
- webcam module
  - illustrated 25, 76
  - removal 81
  - spare part number 25, 76
- webcam, identifying 13
- Windows applications key, identifying 7
- Windows Backup utility 126, 127
- Windows logo key, identifying 7
- Windows recovery 127
- Windows Vista operating system DVD 125
- wireless antenna
  - removal 82
  - spare part number 25, 76
- wireless antennas 15
- wireless light, identifying 10
- wireless module, product description 3
- wireless switch, identifying 10
- WLAN antennas, identifying 15
- WLAN module
  - removal 60
  - spare part number 22, 60
- workstation guidelines 40
- WWAN antennas, identifying 15

WWAN module  
removal 62  
spare part number 62

